



Shell Lubricants SALES PRESENTER



BASIC SAFETY RULES

Health, Security, Safety and Environment



LIFE-SAVING RULES

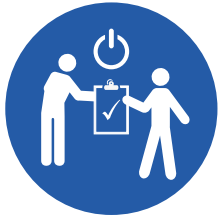

Bypassing Safety Controls

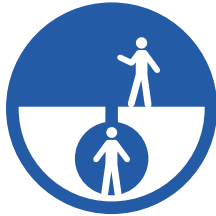

Confined Space



Driving



Energy Isolation



Hot Work



Line of Fire

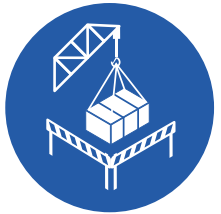

Safe Mechanical Lifting



Work Authorisation



Working at Height



NOTABLE COVID-19 GUIDELINES TO ENSURE SAFETY:



WASH YOUR HANDS
REGULARLY



1 METER SOCIAL
DISTANCING IN PUBLIC
PLACES IS MANDATORY



WEARING FACE MASK
IS MANDATORY OUTSIDE



MORE THAN 5 CUSTOMERS
AT A TIME INSIDE THE
WORKSHOP IS PROHIBITED

**BASIC SAFETY OF USING
SEAT BELTS IN CAR AND
HELMET WHILE RIDING
TWO WHEELERS**



THREE GOLDEN RULES

- 1** COMPLY WITH LAW STANDARDS & PROCEDURES
- 2** INTERVENE IN UNSAFE OR NON-COMPLIANT ACTIONS
- 3** RESPECT OUR NEIGHBOURS

SHELL NAMED #1 GLOBAL LUBRICANTS SUPPLIER FOR THE 16TH YEAR IN A ROW¹

FIRST TO MARKET
PREMIUM LUBRICANTS
MANUFACTURED
FROM NATURAL GAS
IN 100+ COUNTRIES*²



*Based on Global Oil Refining and Processing by Shell & Equivalents

**WORLD-CLASS LUBRICANTS
SUPPLY CHAIN INVESTING TO
MEET MARKET DEMAND⁶**



4 BASE OIL PLANTS

10 GREASE PLANTS

32 BLENDING PLANTS

6 GTL BASE OIL STORAGE HUBS

STRONG NETWORK OF APPROX.
130 MACRO-DISTRIBUTORS
AND **1,860 DISTRIBUTORS**

**DIGITAL SERVICES FOR B2B
AND B2C CUSTOMERS**



MOST PREFERRED LUBRICANT BRANDS¹



**NETWORK OF TECHNOLOGY CENTRES
WITH 300+ R&D SCIENTISTS**
IN USA, CHINA, GERMANY,
INDIA AND JAPAN



**EXPERT TECHNICAL SERVICES SAVE CUSTOMERS
MILLIONS OF DOLLARS A YEAR¹**



MAKING OUR OPERATIONS AND PRODUCTS
MORE SUSTAINABLE FOR THE FUTURE



**DELIVER CUTTING-EDGE PRODUCTS
TO ALL KINDS OF INDUSTRIAL MACHINERY**



**SUCCESSFUL COMMERCIAL RELATIONSHIPS
WITH MANY GLOBAL COMPANIES**



**PUSHING THE BOUNDARIES OF
LUBRICANT TECHNOLOGY ON
RACE TRACKS AROUND THE WORLD**



© 2023 Shell. All rights reserved. Shell is a registered trademark of Shell International Chemical Company Limited. Shell is a registered trademark of Shell International Trading Corporation. Shell is a registered trademark of Shell International Corporation. Shell is a registered trademark of Shell International Energy Services Limited. Shell is a registered trademark of Shell International Products Limited. Shell is a registered trademark of Shell International Services Limited. Shell is a registered trademark of Shell International Technology Limited. Shell is a registered trademark of Shell International Logistics Limited. Shell is a registered trademark of Shell International Finance Limited. Shell is a registered trademark of Shell International Insurance Limited. Shell is a registered trademark of Shell International Risk Management Limited. Shell is a registered trademark of Shell International Legal Services Limited. Shell is a registered trademark of Shell International Human Resources Limited. Shell is a registered trademark of Shell International Information Technology Limited. Shell is a registered trademark of Shell International Communications Limited. Shell is a registered trademark of Shell International Marketing Limited. Shell is a registered trademark of Shell International Sales Limited. Shell is a registered trademark of Shell International Distribution Limited. Shell is a registered trademark of Shell International Customer Service Limited. Shell is a registered trademark of Shell International Support Services Limited. Shell is a registered trademark of Shell International Consulting Limited. Shell is a registered trademark of Shell International Research and Development Limited. Shell is a registered trademark of Shell International Innovation Limited. Shell is a registered trademark of Shell International Sustainability Limited. Shell is a registered trademark of Shell International Environmental Limited. Shell is a registered trademark of Shell International Social and Governance Limited. Shell is a registered trademark of Shell International Ethics and Compliance Limited. Shell is a registered trademark of Shell International Security Limited. Shell is a registered trademark of Shell International Health and Safety Limited. Shell is a registered trademark of Shell International Quality Limited. Shell is a registered trademark of Shell International Performance Limited. Shell is a registered trademark of Shell International Excellence Limited. Shell is a registered trademark of Shell International Leadership Limited. Shell is a registered trademark of Shell International Talent Limited. Shell is a registered trademark of Shell International Diversity and Inclusion Limited. Shell is a registered trademark of Shell International Community Development Limited. Shell is a registered trademark of Shell International Philanthropy Limited. Shell is a registered trademark of Shell International Corporate Social Responsibility Limited. Shell is a registered trademark of Shell International Stakeholder Engagement Limited. Shell is a registered trademark of Shell International Transparency Limited. Shell is a registered trademark of Shell International Accountability Limited. Shell is a registered trademark of Shell International Integrity Limited. Shell is a registered trademark of Shell International Trust Limited. Shell is a registered trademark of Shell International Respect Limited. Shell is a registered trademark of Shell International Responsibility Limited. Shell is a registered trademark of Shell International Fairness Limited. Shell is a registered trademark of Shell International Honesty Limited. Shell is a registered trademark of Shell International Openness Limited. Shell is a registered trademark of Shell International Candour Limited. Shell is a registered trademark of Shell International Sincerity Limited. Shell is a registered trademark of Shell International Authenticity Limited. Shell is a registered trademark of Shell International Reliability Limited. Shell is a registered trademark of Shell International Dependability Limited. Shell is a registered trademark of Shell International Predictability Limited. Shell is a registered trademark of Shell International Consistency Limited. Shell is a registered trademark of Shell International Stability Limited. Shell is a registered trademark of Shell International Security Limited. Shell is a registered trademark of Shell International Safety Limited. Shell is a registered trademark of Shell International Health Limited. Shell is a registered trademark of Shell International Well-being Limited. Shell is a registered trademark of Shell International Quality of Life Limited. Shell is a registered trademark of Shell International Happiness Limited. Shell is a registered trademark of Shell International Satisfaction Limited. Shell is a registered trademark of Shell International Fulfillment Limited. Shell is a registered trademark of Shell International Purpose Limited. Shell is a registered trademark of Shell International Meaning Limited. Shell is a registered trademark of Shell International Impact Limited. Shell is a registered trademark of Shell International Legacy Limited. Shell is a registered trademark of Shell International Reputation Limited. Shell is a registered trademark of Shell International Brand Limited. Shell is a registered trademark of Shell International Identity Limited. Shell is a registered trademark of Shell International Image Limited. Shell is a registered trademark of Shell International Perception Limited. Shell is a registered trademark of Shell International Reputation Limited. Shell is a registered trademark of Shell International Brand Limited. Shell is a registered trademark of Shell International Identity Limited. Shell is a registered trademark of Shell International Image Limited. Shell is a registered trademark of Shell International Perception Limited.

SHELL IN INDIA



Start of operations in India as Burmah Shell

1928



India's first refinery commissioned

1955



Shell Lubricants returns

1993



License for 2000 fuel retail stations obtained

2004



STCB set up

2006



FID on NTCB and launch

2012



BG combination Book Launch

2016

1932

Shell fuels J.R.D. Tata's solo flight from Karachi to Bombay



1976

Burmah Shell nationalised



1997

State of art lube oil blending plant built in Taloja



2005

LNG terminal commissioned in Hazira.



2008

Shell Business Operations set up in Chennai



2015

IT hub set up in Bangalore



2017

STCB, 3rd Global Technology Hub set up with IH2 capabilities



SHELL INDIA

OEM ASSOCIATIONS



BMW Motorrad



JOHN DEERE

Mahindra
Rise.



BLENDING PLANT
IN TALOJA



TECHNOLOGY CENTRE IN BENGALURU

Network & Investment

- Network of about 200 distributors
- More than 53000 mechanics
- **8500 employees**
- **8000 crores investment**

Distribution & Logistics Capability

4 #RDCs and
8 depots PAN INDIA

50 Lac+ Km PA
Primary fleet movement

70000+
Retailers

TECHNOLOGY LEADERSHIP

A PROUD TECHNOLOGY HERITAGE

1960

One of the **1st** to launch a multi-grade engine oil for use in vehicles in all seasons

1970's

1st to pioneer the use of detergents in vehicle oils to help keep engines clean

1980's

1st to launch a commercially successful multi-grade engine oil for heavy duty trucks that 'stayed-in-grade'



WE HELPED DAIMLER SET THE WORLD RECORD FOR THE **MOST FUEL-EFFICIENT** 40-TONNE TRUCK

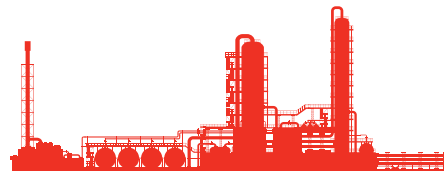

BUILT THE **WORLD'S LARGEST GTL PLANT** PEARL IN QATAR, RESULTING IN 3,500 PATENTS

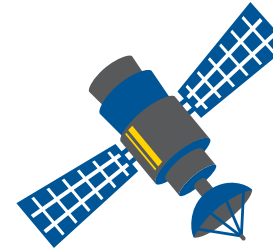

SHELL LUBRICANTS ARE USED EVEN IN THE **EXTREMES OF OUTER SPACE** - 36,000 KMS ABOVE THE EARTH



BUILDING THE **WORLD'S LARGEST SHIP**, THE WORLD'S **1st** FLOATING LNG PLANT

PRODUCT PLUS SERVICES

Cutting Edge Technology



Shell LubeVideoCheck

LubeVideoCheck is a state-of-the-art fiber-optic tool that allows us to inspect key internal engine components such as the cylinder head, valves, cylinder walls and pistons without dismantling the engine itself.

Using
Shell Rimula

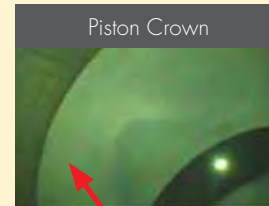

Piston in good condition

Using other oil

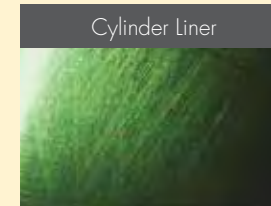

Wear due to poor lubrication



Valves in good condition



Shell LubeAnalyst

LubeAnalyst is an oil and equipment condition monitoring service, which helps you to keep your vehicles and equipment running smoothly by identifying potential failures before they become critical.

**EXPERT
TECHNICAL
SERVICES**
SAVE CUSTOMERS
MILLIONS OF
DOLLARS A YEAR



Shell LubeChat

Our new online chat tool gives you answers to questions about oils and lubes.

Shell
ADVANCE
MOTORCYCLE OILS

Technical
Partner



WHY SHELL ADVANCE?

At Shell, we believe in catering to all of your business needs. From product and technology efficacies to training and support tools, we are here to partner with you, every step of the way.

1

Shell PUREPLUS TECHNOLOGY

A revolutionary process that delivers crystal clear base oil made from natural gas with virtually no impurities – making it 99.5% pure, giving you longer lasting engine performance.



This technology helps to prevent dirt particles sticking together to form deposit, keeping your engine cleaner so that it can be more efficient.

2

COMPLETE PROTECTION



PROTECTS
HORSEPOWER



ENHANCED
FUEL ECONOMY



SUPERIOR WEAR
PROTECTION



HIGH TEMPERATURE
PROTECTION



KEEPS
PISTONS CLEAN

COMPLETE PROTECTION FOR YOUR BIKE WITH SHELL ADVANCE



3

Technical
Partner

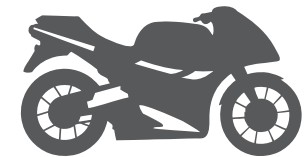

Our partnership with Ducati allows us to transfer knowledge gained from the track to Shell's products for the road, giving you a competitive and high quality product in market.

POWER OF SHELL ADVANCE IN EXTREME RACING CONDITIONS

Transferring Race Track Technology for Use on Roads

STAY POWERFUL
354.9 KM/H



3x FASTER THAN A CHEETAH

Shell Advance has helped power Ducati to a MotoGP™ top speed record

COOL INSIDE
175°C



3x HOTTER THAN ASIA'S RECORD TEMPERATURE

Shell Advance helps cool the lubricated parts of the Ducati engine in extreme temperatures of MotoGP™

RIDE LONGER
17,000 RPM



5x GREATER THAN THE FAN OF A 777 JET ENGINE

Shell Advance helps deliver fuel efficiency to Ducati in extreme engineering conditions of MotoGP™

EXCLUSIVE
Technical
Partner



SHELL PUREPLUS TECHNOLOGY

Shell PUREPLUS TECHNOLOGY

Today's bikes need an oil that does more to improve performance and engine life. Base oil is key as it can be up to 90% of an oil. Shell has developed a new approach: making synthetic motor oils from NATURAL GAS. It uses PurePlus Technology, a revolutionary process that delivers crystal clear base oil made from natural gas with virtually no impurities – making it 99.5% pure.

Shell PurePlus Technology produces clean and strong base oils with:

- Virtually none of the impurities found in crude oil
- Stronger molecular bonds for long-lasting engine performance
- Enhanced viscosity, friction and volatility performance compared with traditional group II and group III base oils

TRADITIONAL CRUDE OIL



Muddy water



Runs through
small filter



Still impure



IMAGINE FILTERING A CUP OF MUDDY WATER. IT WOULD STILL CONTAIN SOME IMPURITIES. THIS IS SIMILAR TO HOW BASE OIL IS MADE FROM CRUDE OIL.

GAS TO LIQUIDS

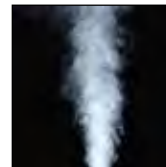

Steam



Pure liquid



BASE OIL MADE FROM NATURAL GAS USING SHELL PUREPLUS TECHNOLOGY.

NOW IMAGINE CONDENSING STEAM. THE RESULTING WATER WOULD BE PURE. THIS IS SIMILAR TO USING SHELL PUREPLUS TECHNOLOGY TO MAKE BASE OIL FROM NATURAL GAS.

SHELL ACTIVE CLEANSING TECHNOLOGY

Shell Advance is made from pure and clear base oil, combining with a motorcycle-specific additive pack with unique Active Cleaning Technology. It helps to cleanse and keep the engine cleaner. A clean motorcycle engine helps provide better engine efficiency, performance and protection.

PREVENTS SLUDGE FORMATION

By locking away dirt particles

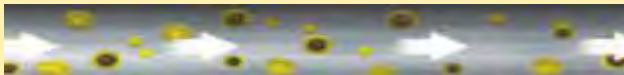

Sludge built up in competitor products

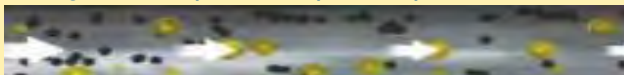

Better Engine Cleanliness as compared to competitors

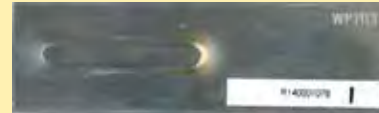

Shell Advance Ultra



Leading competitor



Shell Advance AX7

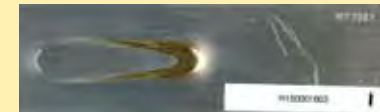

Leading competitor



**SMOOTHER, QUIETER AND MORE
RESPONSIVE ENGINE**

*Cleanliness results are based on the Micro Coker Test MCT, GFC Lu 27-T-07. The Microcoking Test Method (MCT) is a French industry standard test (method number is GFC Lu 27-T-07). The MCT evaluates the propensity of lubricating oil to form deposits when subjected to high temperatures (thermal stability).

Shell
ADVANCE
MOTORCYCLE OILS

PRODUCTS TIERING



ADVANCE AX STAR
VALUE FOR MONEY



ADVANCE AX3
RELIABLE PROTECTION



ADVANCE AX5
EXTENDED ENGINE LIFE



ADVANCE AX7
SUPERIOR ACCELERATION



ADVANCE FUEL SAVE
EXPERTLY ENGINEERED TO GIVE EXTRA MILEAGE



ADVANCE ULTRA
SUPERIOR ACCELERATION

SHELL ADVANCE ULTRA

Shell Advance Ultra with Pure Plus Technology, is a top tier 4 stroke Premium synthetic motorcycle engine oil. The 100% synthetic Advance 4T Ultra is made from this pure and clear base oil, combined with a motorcycle-specific additive pack with unique Active Cleansing Technology. It helps to cleanse and keep the engine cleaner. A clean motorcycle engine helps provide better engine efficiency, performance and protection.



SPECIFICATIONS

SAE Viscosity Grade: 10W-40, 15W-50

API SN; JASO MA2

DESIGNED FOR:



TECHNICAL BENEFITS AND END CONSUMER BENEFITS



IMPROVES FUEL ECONOMY

RIDE 5KM FARTHER PER LTR OF FUEL COMPARED TO A PREMIUM MINERAL OIL



RIDE LONGER ON SAME AMOUNT OF FUEL



KEEP PISTONS AND ENGINES CLEAN

49% CLEANER ENGINES THAN A LEADING COMPETITOR PRODUCT



CLEAN AND MORE RESPONSIVE ENGINE WHICH MEANS MORE POWER



SUPERIOR WEAR PROTECTION

36% BETTER WEAR PROTECTION AGAINST INDUSTRY LIMITS



LONGER LIFE OF ALL CRITICAL PARTS RUNNING IN THE ENGINE



HIGH TEMPERATURE PROTECTION

71% BETTER PROTECTION AT HIGH TEMPERATURE THAN A LEADING COMPETITOR PRODUCT



OIL DOES NOT DEGRADE AT HIGH TEMPERATURE AND WORKS LIKE NEW



RETAINS HORSEPOWER

20000 KMS POWER RETENTION CLAIM



DOESN'T LET YOUR BIKE LOSE POWER OVER TIME

SHELL ADVANCE FUEL SAVE

Expertly Engineered to give extra mileage



5KM/L EXTRA* MILEAGE

HIGHEST SPEC API SN JASO MA2

OEM RECOMMENDED VISCOSITY 10W30

EXTRA SAVINGS (UP TO ₹2500)

SPECIFICATIONS

SAE Viscosity Grade: 10W-30



API SN; JASO MA2

DESIGNED FOR:



Shell Advance Fuel Save is a fully synthetic motorcycle engine oil for the customers who are daily riders with higher running hours on the road. Fuel Save is expertly engineered to give extended fuel economy to consumers and contribute to sustainability by reducing per km fuel consumption. Shell Advance Fuel Save is blended with Shell PurePlus Technology that gives 99.5% pure base oil and is expertly engineered to give extra mileage.

ADVANCE FUEL SAVE - SAVINGS CALCULATION

	NORMAL OIL								
	2500 km running; 50 kmpl mileage; ₹110 per ltr petrol	»	2500/50	»	50 ltrs of petrol	»	50* 110	»	₹5500 spent on fuel
									₹500 SAVINGS
	SHELL ADVANCE FUEL SAVE								
	2500 km running; 55 kmpl mileage; ₹110 per ltr petrol	»	2500/55	»	45.5 ltrs of petrol	»	45.5* 110	»	₹5000 spent on fuel

5L PETROL SAVED IN ONE RIDE



₹500 AMOUNT SAVED IN ONE RIDE



₹2500 ASSUMING RIDER COMPLETES 5 CYCLES OF 2500 KMS IN A YEAR, TOTAL SAVINGS (500*5)

SAVINGS UP TO **₹2500****



* We recorded 5km¹ per litre more on a fleet of bikes after running 12,000 km, under realistic riding condition.
** Savings may vary depending upon age & CC of vehicle, driving behaviour, road conditions & journey pattern.

SHELL ADVANCE AX7

Shell Advance AX7 is a premium semi synthetic 4 stroke motorcycle engine oil. The unique Active Cleansing Technology additive helps to cleanse and keep the motorcycle engine cleaner. A clean motorcycle engine will run more efficiently and will be better protected. Shell Advance 4T AX7 4 stroke motorcycle engine oil meets the requirements of most motorcycle manufacturers.



SPECIFICATIONS

SAE Viscosity Grade: 10W-40, 15W-50

API SN; JASO MA2

DESIGNED FOR:



TECHNICAL BENEFITS AND END CONSUMER BENEFITS



IMPROVES FUEL ECONOMY

RIDE 3KM FARTHER PER LTR OF FUEL COMPARED TO A PREMIUM MINERAL OIL



RIDE LONGER ON SAME AMOUNT OF FUEL



KEEP PISTONS AND ENGINES

CLEAN 10% CLEANER ENGINES THAN A LEADING COMPETITOR PRODUCT



CLEAN AND MORE RESPONSIVE ENGINE WHICH MEANS MORE POWER



SUPERIOR WEAR PROTECTION

36% BETTER WEAR PROTECTION AGAINST INDUSTRY LIMITS



LONGER LIFE OF ALL CRITICAL PARTS RUNNING IN THE ENGINE



HIGH TEMPERATURE PROTECTION

29% BETTER PROTECTION AT HIGH TEMPERATURE THAN A LEADING COMPETITOR PRODUCT



OIL DOES NOT DEGRADE AT HIGH TEMPERATURE AND WORKS LIKE NEW



RETAINS HORSEPOWER

NO POWER LOSS AT THE END OF 12000 KMS.



DOESN'T LET YOUR BIKE LOSE POWER OVER TIME

SHELL ADVANCE AX5

Shell Advance AX5 is a Premium mineral 4 stroke motorcycle engine oil. It is made up of premium mineral base oil and motorcycle-specific additive pack with Active Cleansing Technology. During the stop-start cycle of commuter journeys, mid-size engines require reliable oil performance under a range of conditions.



SPECIFICATIONS

SAE Viscosity Grade: 15W-50, 20W-50
20W-40, 10W-30

API SL; JASO MA2

TECHNICAL BENEFITS AND END CONSUMER BENEFITS



KEEP PISTONS AND ENGINES CLEAN
49% CLEANER ENGINES THAN A LEADING COMPETITOR PRODUCT



CLEAN AND MORE RESPONSIVE ENGINE WHICH MEANS MORE POWER



SUPERIOR WEAR PROTECTION
29% BETTER WEAR PROTECTION AGAINST INDUSTRY LIMITS



LONGER LIFE OF ALL CRITICAL PARTS RUNNING IN THE ENGINE



HIGH TEMPERATURE PROTECTION
48% BETTER PROTECTION AT HIGH TEMPERATURE



OIL DOES NOT DEGRADE AT HIGH TEMPERATURE AND WORKS LIKE NEW

DESIGNED FOR:



SHELL ADVANCE AX3, AX STAR

Technical benefits and end consumer benefits

Shell Advance AX3 is an entry, tier 4 stroke motorcycle engine oil. It is an ideal oil for small, hot-running, hard-working engines that require reliable oil performance for continuous protection. It offers high oil performance reliability to help protect and clean your engine between oil changes.

KEEPS PISTONS AND ENGINES CLEAN

↓
CLEAN AND MORE RESPONSIVE ENGINE WHICH MEANS MORE POWER

SUPERIOR WEAR PROTECTION

↓
LONGER LIFE OF ALL CRITICAL PARTS RUNNING IN THE ENGINE



SPECIFICATIONS (AX3, AX STAR)

SAE Viscosity Grade: 20W40

API SL*, JASO MA

*Meet SL limits for VTW
DESIGNED FOR:



Advance 4T AX Star 20W-40 is our basic-tier 4 stroke motorcycle engine oil made up of quality mineral base oil and additive pack that help to keep the motorcycle engine clean. Advance 4T AX Star 20W-40 four-stroke motorcycle engine oil meets the requirements of most motorcycle manufacturers.



SHELL ADVANCE SCOOTER OIL

WHY YOU SHOULD RECOMMEND **SHELL ADVANCE SCOOTER OIL**

Premium Mineral Oil with Shell Active cleansing technology helps protect and keep your engine clean under a range of road conditions.

SPECIFICATIONS

SAE Viscosity Grade: 10W30
API SL; JASO MB

DESIGNED FOR SCOOTER



Semi-synthetic scooter oil with Shell Active Cleansing Technology helps protect and keep your engine clean in all types of road conditions.

SPECIFICATIONS

SAE Viscosity Grade: SAE 10W30
API SM; JASO MB

DESIGNED FOR SCOOTER



RETAINS STABLE VISCOSITY
42% LONGER*
THAN THE API LIMIT



CLEANS SCOOTER ENGINES
33% BETTER* THAN
LEADING COMPETITOR



RETAINS OXIDATION STABILITY
42% LONGER*
THAN LEADING COMPETITOR



SMOOTH RIDE**



DURABLE OIL



STABLE OIL

ADVANCE FUEL SAVE SCOOTER OIL

The Right Scooter Oil To Outside City Roads

Shell Advance Fuel Save is a fully synthetic scooter engine oil that is expertly engineered to give extended fuel economy to consumers. It is formulated with PurePlus Technology that gives better flow across all temperatures.



SPECIFICATIONS

SAE Viscosity Grade: 10W30

API SN; JASO MB

DESIGNED FOR:



TECHNICAL BENEFITS AND END CONSUMER BENEFITS



EXPERTLY ENGINEERED TO IMPROVE FUEL ECONOMY - 5KM/L EXTRA MILEAGE



REDUCE FRICTION BY 20%



FULLY SYNTHETIC SCOOTER OIL WITH BS6 COMPLIANCE



FORMULATED WITH PUREPLUS TECHNOLOGY THAT GIVES 99.5 PURE BASE OIL THAT KEEPS ENGINE CLEAN

WHY SCOOTER OILS ?

Motorcycles and scooters are two different machines with varying needs and characteristics for optimum performance.

Similar to how you wouldn't put petrol in a diesel car, you shouldn't put motorcycle oil in a scooter.

We are here to help you understand the difference between motorbike and scooter oil, and the benefits in using the right oil.

YOUR SCOOTER
ISN'T A MOTOR BIKE
**SO DON'T GIVE
IT MOTORBIKE OIL.**



SCOOTER ENGINES
USUALLY OPERATE AT
**HIGHER
TEMPERATURES**



SCOOTER HAVE AN
**AUTOMATIC
CLUTCH,** NOT
A MANUAL ONE.

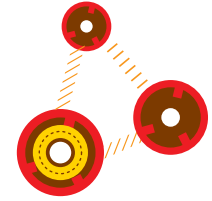

SCOOTER ENGINES
CAN RUN AT
HIGHER RPMs



SCOOTER
ENGINES ARE
USALLY **SMALLER**

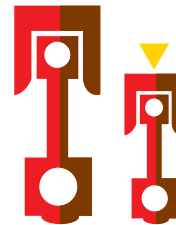

SCOOTERS CAN HAVE
**LONGER DRAIN
INTERVALS**



SHELL HONDA CO-BRANDED RANGE FOR MOTORCYCLE AND SCOOTER OILS



Formulation Partnership

Right for your Honda ride



POWER TO RIDE

Conditions in a scooter engine are harsher than in a motorcycle engine. **Shell Advance Honda is a Premium Performance Scooter Oil** designed to meet the needs of all Honda Scooter engines.

SHELL ADVANCE 4T SCOOTER OIL 10W-30 MB

Conditions in a scooter engine are harsher than in a motorcycle engine. **Shell Advance Honda is a Premium Performance Scooter Oil** designed to meet the needs of all Honda Scooter engines.

IMPROVED PICK-UP  **AND ACCELERATION**

BETTER FUEL ECONOMY,
LOWER MAINTENANCE COST



 **PROTECTS ENGINE IN HIGH TEMPERATURE**
WORKING CONDITIONS

RELIABLE PROTECTION
AGAINST WEAR & TEAR
AND SMOOTHER RIDE 



SHELL ADVANCE 4T ENGINE OIL 10W-30 MA

Bike engines require reliable engine performance under a range of driving conditions. **Shell Advance Honda is a Premium Performance Engine Oil** designed to meet the needs of all Honda Motorcycle engines.









 **KEEPS ENGINE COOL**
EVEN IN HOT CLIMATE
FOR COMFORTABLE AND SMOOTH RIDE

LOW WEAR  **EVEN IN START-STOP CITY**
DRIVING CONDITIONS

 **SMOOTHER**
GEAR SHIFTING



SHELL ADVANCE PRODUCT PORTFOLIO

	GOOD		BETTER		BEST				
PRODUCT	 ADVANCE AX STAR	 ADVANCE AX3	 ADVANCE AX5 SCOOTER	 ADVANCE AX5	 ADVANCE AX7 SCOOTER	 ADVANCE AX7	 ADVANCE FUEL SAVE SCOOTER	 ADVANCE ULTRA	 ADVANCE ULTRA
BENEFIT	Value for Money	Good wear protection	Reduced noise & vibration	Extended engine life	Smoother ride and longer engine life	Superior Acceleration with slightest touch	Enhanced Fuel economy	Expertly Engineered to give extra mileage	Power and Performance to outdrive anything
OIL TYPE	Mineral	Mineral	Premium Mineral	Premium Mineral	Semi-Synthetic	Semi-Synthetic	Fully Synthetic	Fully Synthetic	Fully Synthetic
VISCOSITY	20W-40	20W-40	10W-30	10W-30, 20W-40, 20W-50, 15W-50	10W-30	10W-40, 15W-50	10W-30	10W-30	10W-40,15W-50
SPECIFICATION	API SL*, JASO MA	API SL*, JASO MA	API SL, JASO MB	API SL, JASO MA2	API SM, JASO MB	API SN, JASO MA2	API SN, JASO MB	API SN, JASO MA2	API SN, JASO MA2
BS6 READY	NA	NA	✓	✓	✓	✓	✓	✓	✓

SHELL ADVANCE SARAL POINTS



ADVANCE ULTRA



AX7



AX5



AX5 SCOOTER



AX7 SCOOTER



High performance bikes loose power and efficiency over time.

Not using a dedicated engine oil can lead to sluggish engine performance and poor acceleration

Deposits build up in bikes can result in reduced engine life

Stop Start City traffic results into poor engineperformance

Scooter engines operate at high temp & stressful conditions



PurePlus Technology gives crystal clear base oil that pushes engine performance to highest standards giving long lasting protection.

Active Cleansing Technology keeps engine cleaner and make them responsive

Active Cleansing Technology gives cleaner, smoother and quieter engines

Active Cleansing Technology helps to prevent dirt particles sticking together to form deposits.

Active Cleansing Technology helps to prevent dirt particles sticking together to form deposits.



Power and Performance to outride anything

Superior Acceleration with slightest touch

Cleaner engines lead to longer engine life

Reduced noise & Vibration

Smoother Ride & Longer Engine Life

Rukna Mushkil Hai

Shell Advance Recommended Products for your bike

Hero



MOTORCYCLE MODEL	CC	SHELL RECOMMENDATION
ACHIEVER/IMPULSE/HUNK	150 CC	Shell Advance Fuel Save 10W-30/Advance AX7 10W-40
GLAMOUR / GLAMOUR FI/ GLAMOUR XTEC	125 CC	Shell Advance Fuel Save 10W-30/ Advance AX5 10W-30
HF DAWN	97 CC	Shell Advance AX5 10W-30/Advance Fuel Save 10W-30
HF DELUXE/HF DELUXE ECO	97 CC	Shell Advance AX5 10W-30/Advance Fuel Save 10W-30
HF DELUXE/HF DELUXE ECO	97 CC	Shell Advance AX5 10W-30/Advance Fuel Save 10W-30
KARIZMA/KARIZMA/KARIZMA ZMR	223 CC	Shell Advance Ultra 10W-40
SPLENDOUR/SPLENDOUR PLUS/ SPLENDOR PLUS XTEC	97 CC	Shell Advance AX5 10W-30/Advance Fuel Save 10W-30
SUPER SPLENDOUR	125 CC	Shell Advance Fuel Save 10W-30/ AX5 10W-30
SPLENDOUR ISMART 110	113 CC	Shell Advance Fuel Save 10W-30/ AX5 10W-30
PASSION XTEC /PASSION PRO/ PLEASURE PLUS	110 CC/113 CC	Shell Advance Fuel Save 10W-30/ AX5 10W-30
XTREME SPORTS/XTREME 200	150 CC	Shell Advance Fuel Save 10W-30/ Advance AX7 10W-40
CD DAWN/CD DELUXE	97 CC	Shell Advance AX5 10W-30/Advance Fuel Save 10W-30
XPULSE 200/200 4V EXTREME 200S	200 CC	Shell Advance Ultra 10W-40/AX7 10W-40
XTREME 160R/XTREME 200S	163 CC/200 CC	Shell Advance Fuel Save/ Ultra 10W-40
IGNITOR	125 CC	Shell Advance Fuel Save 10W-30/Advance AX5 10W-30

Honda



MOTORCYCLE MODEL	CC	SHELL RECOMMENDATION
SHINE 100	125/100 CC	Shell Advance Fuel Save 10W-30/Advance AX5 10W-30
LIVO/CB TWISTER	109 CC	Shell Advance Fuel Save 10W-30/Advance AX5 10W-30
UNICORN 160	163 CC	Shell Advance Fuel Save 10W-30/Advance AX7 10W-40
CB UNICORN DAZZLER/LIVO	150 CC	Shell Advance Fuel Save 10W-30
CD 110 DREAM	110 CC	Shell Advance Fuel Save 10W-30/Advance AX5 10W-30
X-BLADE	162 CC	Shell Advance Fuel Save 10W-30/Advance AX7 10W-40
CBF STUNNER	125 CC	Shell Advance Fuel Save 10W-30/AX5 10W-30
CBR 150R	150 CC	Shell Advance Fuel Save 10W-30
CBR 250R	250 CC	Shell Advance Ultra 15W-50
CB1000R /CBR1000RR	999 CC	Shell Advance Ultra 15W-50
SP 125	125 CC	Shell Advance Fuel Save 10W-30/Advance AX5 10W-30
HORNET	184 CC	Shell Advance Ultra 15W-50
VFR1200F	1200 CC	Shell Advance Ultra 15W-50
DREAM YUGA/DREAM NEO	109 CC	Shell Advance Fuel Save 10W-30/Advance AX5 10W-30
H'NESS CB350	345 CC	Shell Advance Ultra 15W-50
HONDA REBEL	500 CC	Shell Advance Ultra 15W-50
CB200X/CB300R/CB350RS/CB300F/ CB200X/CBR650R/CB500X	200 to 650 CC	Shell Advance Ultra 15W-50
CBR 1000RR/GOLDWING/CRF AFRICA TWIN	1000 CC & above	Shell Advance Ultra 15W-50

Rukna Mushkil Hai

Shell Advance Recommended Products for your bike

Bajaj



MOTORCYCLE MODEL	CC	SHELL RECOMMENDATION
BOXER	150 CC	Shell Advance Fuel Save 10W-30/Advance AX7 10W-40
CALIBER 115	115 CC	Shell Advance Fuel Save 10W-30/Advance AX5 10W-30
CT 100/CT 110 X/CT 125X	100 CC/125 CC	Shell Advance Fuel Save 10W-30/Advance AX5 10W-30
DISCOVER 100/125	100 CC	Shell Advance Fuel Save 10W-30/Advance AX5 10W-30
DOMINAR 250/400	250/373 CC	Shell Advance Ultra 15W-50
ELIMINATOR	174 CC	Shell Advance Ultra 15W-50
PLATINA 100/110/125	100 to 125 CC	Shell Advance Fuel Save 10W-30/Advance AX5 10W-30
XCD 125/135	125/135 CC	Shell Advance Fuel Save 10W-30/Advance AX5 10W-30
AVENGER 150/AVENGER STREET 160	150/160 CC	Shell Advance Fuel Save 10W-30
AVENGER CRUISE 220/220 DTSI/400	220/400 CC	Shell Advance Ultra 15W-50
DISCOVER 150	150 CC	Shell Advance Fuel Save 10W-30
NINJA 250/300/650R	250/300/650 CC	Shell Advance Ultra 15W-50
PULSAR NS 200/N 250/F250 RS 200/220 F/180F	200/220/250 CC	Shell Advance Ultra 15W-50
PULSAR NS125/PULSAR NS160	125/160 CC	Shell Advance Fuel Save 10W-30/Advance AX5 10W-30
PULSAR 150/PULSAR 135/PULSAR 125/NS125	125/135/150 CC	Shell Advance Fuel Save 10W-30/Advance AX5 10W-30

TVS



MOTORCYCLE MODEL	CC	SHELL RECOMMENDATION
APACHE RTR 160 4V/RTR 160/ APACHE 150	160 CC	Shell Advane Fuel Save 10W-30/Advance AX7 10W-40
APACHE RTR 180	177 CC	Shell Advance Ultra 10W-40/Advance AX7 10W-40
APACHE RTR 200 4V /APACHE RR310	200/310/312 CC	Shell Advance Ultra 15W-50
RONIN	226 CC	Shell Advance Ultra 15W-50
RADEON/JIVE/SPORT	109/110 CC	Shell Advane Fuel Save 10W-30/ Advance AX5 10W-30
RAIDER 125	125 CC	Shell Advane Fuel Save 10W-30/ Advance AX5 10W-30
FIERO	125/150 CC	Shell Advane Fuel Save 10W-30/ Advance AX5 10W-30
CENTRA	100 CC	Shell Advane Fuel Save 10W-30/ Advance AX5 10W-30
FLAME DS 125/SR 125	125 CC	Shell Advane Fuel Save 10W-30/ Advance AX5 10W-30
MAX 100/4R/125	125 CC	Shell Advane Fuel Save 10W-30/ Advance AX5 10W-30
XL100 HEAVY DUTY/XL100 COMFORT	100 CC	Shell Advane Fuel Save 10W-30/ Advance AX5 10W-30
METRO PLUS/METRO	100 CC	Shell Advane Fuel Save 10W-30/ Advance AX5 10W-30
STAR CITY PLUS 110/STAR LX	100 CC	Shell Advane Fuel Save 10W-30/ Advance AX5 10W-30
RONIN	225 CC	Shell Advance Ultra 15W-50
PHOENIX 125	125 CC	Shell Advane Fuel Save 10W-30/ Advance AX5 10W-30
VICTOR GLX/GX/125	100/125CC	Shell Advane Fuel Save 10W-30/ Advance AX5 10W-30

Rukna
Mushkil Hai

Shell Advance Recommended Products for your bike

Royal Enfield



MOTORCYCLE MODEL	CC	SHELL RECOMMENDATION
THUNDER BIRD 350/ CLASSIC 350	350 CC	Shell Advance AX7 15W-50
HUNTER 350	350 CC	Shell Advance AX7 15W-50
CLASSIC/CLASSIC DESERT STORM	346 to 499 CC	Shell Advance AX7 15W-50
THUNDER BIRD 500	500 CC	Shell Advance AX7 15W-50
ROYAL ENFIELD HUNTER	350 CC	Shell Advance AX7 15W-50
HIMALAYAN/SCRAM	411 CC	Shell Advance AX7 15W-50
METEOR/SUPER METEOR	350/650 CC	Shell Advance Ultra 15W-50/AX7 15W-50
INTERCEPTOR/CONTINENTAL GT	650 CC	Shell Advance Ultra 15W-50
CLASSIC 500/BATTLE GREEN/ CHROME/DESERT STORM	500 CC	Shell Advance AX7 15W-50
BULLET ELECTRA TWIN SPARK	350 CC	Shell Advance AX7 15W-50
BULLET 350	346 CC	Shell Advance AX7 15W-50
BULLET 500	500 CC	Shell Advance AX7 15W-50
BULLET ELECTRA DELUXE	500 CC	Shell Advance AX7 15W-50
BULLET ELECTRA EFI	500 CC	Shell Advance AX7 15W-50

Yamaha



MOTORCYCLE MODEL	CC	SHELL RECOMMENDATION
FZ1	998 CC	Shell Advance Ultra 10W-40
FZ 8	779 CC	Shell Advance Ultra 10W-40
FZ 16	153 CC	Shell Advance AX7 10W-40
FZ S/FZ S FI /FZS-FI V3/FAZER F1	150 CC	Shell Advance AX7 10W-40
FZ/FZ X/FZ FI/FZ S FI/FZ X/V3	150 CC	Shell Advance AX7 10W-40
FZ 25/FZS 25	250 CC	Shell Advance Ultra 10W-40
CRUX	106 CC	Shell Advance AX5 20W-40
ENTICER/YD 125/SS 125/AEROX/ FASCINO	125 CC	Shell Advance AX5 20W-40
LIBERO	105 CC	Shell Advance AX5 20W-40
SZ-R/SZ-X	153 CC	Shell Advance AX7 10W-40
VMAX	1679 CC	Shell Advance Ultra 15W-50
YBR 110/125/YBX/RAY ZR 125	110 CC	Shell Advance AX5 20W-40
YZF R1M R1	998 CC	Shell Advance Ultra 15W-50
MT 09	850 CC	Shell Advance Ultra 15W-50
MT 15 V2/R15S/AEROX/R15 V4	155 CC	Shell Advance AX7 10W-40
YZF R3/R15/MT 03	321 CC	Shell Advance Ultra 10W-40
YZF R15/R15S V3/YZF R15 V4	155 CC	Shell Advance AX7 10W-40

Rukna Mushkil Hai

Shell Advance Recommended Products for your bike

Suzuki



MOTORCYCLE MODEL	CC	SHELL RECOMMENDATION
SUZUKI GS125R/HEAT ALLOY	125 CC	Shell Advance AX7 10W-40/ Advance AX5 10W-30
SUZUKI SLING SHOT/SLING SHOT PLUS/ACCESS	125 CC	Shell Advance AX7 10W-40/ Advance AX5 10W-30
SUZUKI BURGMAN STREET	125 CC	Shell Advance AX7 10W-40/ Advance AX5 10W-30
SUZUKI ZEUS 125EU/ZEUS 125XCD/ACCESS	125 CC	Shell Advance AX7 10W-40/ Advance AX5 10W-30
INTRUDER 150	155 CC	Shell Advance AX7 10W-40
SUZUKI BANDIT 1250S	1250 CC	Shell Advance Ultra 15W-50
SUZUKI GLADIUS	645 CC	Shell Advance Ultra 15W-50
SUZUKI GSX R600/GSX R750/GSX R1000R/GSX R1000	600/750/1000 CC	Shell Advance Ultra 15W-50
GIXXER/GIXXER SF 155	155 CC	Shell Advance AX7 10W-40
GIXXER/GIXXER SF 250	250 CC	Shell Advance Ultra 15W-50
SUZUKI R1000 ABS	1000 CC	Shell Advance Ultra 15W-50
V-STROM SX/650 XT/1050	250 CC/645 CC/ 1037 CC	Shell Advance Ultra 15W-50
SUZUKI GW 250	250 CC	Shell Advance Ultra 15W-50
SUZUKI HAYABUSA	1340 CC	Shell Advance Ultra 15W-50
KATANA	999 CC	Shell Advance Ultra 15W-50

KTM



MOTORCYCLE MODEL	CC	SHELL RECOMMENDATION
DUKE 200/RC 200	200 CC	Shell Advance Ultra 15W-50
125 DUKE/RC 125/250 DUKE/ADVENTURE 250	125 CC/250 CC	Shell Advance Ultra 15W-50
DUKE 390/RC 390/390 ADVENTURE	373 CC	Shell Advance Ultra 15W-50

DSK Benelli



MOTORCYCLE MODEL	CC	SHELL RECOMMENDATION
TNT 250/TRK 251	250 CC	Shell Advance AX7 15W-50/ Ultra 15W-50
TNT 300/302R	300 CC	Shell Advance AX7 15W-50/ Ultra 15W-50
TNT 899	899 CC	Shell Advance Ultra 15W-50
IMPERIALE 400	374 CC	Shell Advance Ultra 15W-50
TRK 502X/TRK 502/502C	500 CC	Shell Advance Ultra 15W-50
LEONCINO 500	500 CC	Shell Advance Ultra 15W-50
TNT 600	600 CC	Shell Advance Ultra 15W-50

Rukna Mushkil Hai

Shell Advance Recommended Products for your bike

DSK Hyosung



MOTORCYCLE MODEL	CC	SHELL RECOMMENDATION
AQUILA/AQUILA PRO	250 CC/447 CC	Shell Advance Ultra 15W-50
GT 650/GT 650 R	647 CC	Shell Advance Ultra 15W-50
ST7	678 CC	Shell Advance Ultra 15W-50
GT 250 R	300 CC	Shell Advance Ultra 15W-50

Harley Davidson



MOTORCYCLE MODEL	CC	SHELL RECOMMENDATION
STREET 750/STREET GLIDE	750 CC	Shell Advance Ultra 15W-50
IRON 883	883 CC	Shell Advance Ultra 15W-50
FAT BOY 114/FAT BOB 114/STREET GLIDE/ROAD GLIDE/HERITAGE CLASSIC	1868 CC	Shell Advance Ultra 15W-50
SPORTSTER/PAN AMERICA	1250 CC	Shell Advance Ultra 15W-50
NIGHTSTER	975 CC	Shell Advance Ultra 15W-50
ROAD KING	1745 CC	Shell Advance Ultra 15W-50
FORTY EIGHT	1200 CC	Shell Advance Ultra 15W-50

BMW Motorrad



MOTORCYCLE MODEL	CC	SHELL RECOMMENDATION
R 1200 R	1170 CC	Shell Advance Ultra 15W-50
R 1300	1293 CC	Shell Advance Ultra 15W-50
G310 RR/G310 R/G 310 GS	312 CC	Shell Advance Ultra 15W-50
S 1000 RR	999 CC	Shell Advance Ultra 15W-50
K 1600 GT	1649 CC	Shell Advance Ultra 15W-50

Triumph



MOTORCYCLE MODEL	CC	SHELL RECOMMENDATION
TIGER	799 CC	Shell Advance Ultra 15W-50
STREET/STREET TWIN/STREET TRIPLE	765 CC	Shell Advance Ultra 15W-50
BONNEVILLE T100 / T120/SPEED TWIN	900 CC/1200 CC	Shell Advance Ultra 15W-50
ROCKET 3	2458 CC	Shell Advance Ultra 15W-50
TRIDENT 660	660 CC	Shell Advance Ultra 15W-50
TIGER 900/STREET SCRAMBLER/SPEED TWIN	900 CC	Shell Advance Ultra 15W-50
BONNEVILLE SPEEDMASTER/ BOBBER	1200 CC	Shell Advance Ultra 15W-50
SPEED TRIPLE/TIGER	1160 CC	Shell Advance Ultra 15W-50
TIGER SPORT	660 CC/850 CC	Shell Advance Ultra 15W-50

Shell
ADVANCE
MOTORCYCLE OILS



**OUTRIDE
ANYTHING**

SHELL ADVANCE SCOOTER

Recommendation Chart

TVS



OEM	BIKE MODEL	SHELL LUBE RECOMMENDATION
TVS	NEO X3i	Shell Advance AX7/AX5 10W-30
TVS	Rockz	Shell Advance AX7/AX5 10W-30
TVS	Scooty Pep	Shell Advance AX7/AX5 10W-30
TVS	Creon	Shell Advance AX7/AX5 10W-30
TVS	NtorQ	Shell Advance AX7/AX5 10W-30
TVS	Jupiter	Shell Advance AX7/AX5 10W-30
TVS	Scooty Pep Plus	Shell Advance AX7/AX5 10W-30
TVS	Streak	Shell Advance AX7/AX5 10W-30
TVS	Tormax 150	Shell Advance AX7/AX5 10W-30
TVS	Scooty Zest	Shell Advance AX7/AX5 10W-30
TVS	Jupiter	Shell Advance AX7/AX5 10W-30
TVS	Wigo	Shell Advance AX7/AX5 10W-30

YAMAHA



OEM	BIKE MODEL	SHELL LUBE RECOMMENDATION
Yamaha	fascino	Shell Advance AX7/AX5 10W-30
Yamaha	Aerox 155	Shell Advance AX7/AX5 10W-30
Yamaha	Ray ZR 125	Shell Advance AX7/AX5 10W-30
Yamaha	alpha	Shell Advance AX7/AX5 10W-30
Yamaha	Ray Z	Shell Advance AX7/AX5 10W-30
Yamaha	Ray ZR	Shell Advance AX7/AX5 10W-30

PIAGGIO



OEM	BIKE MODEL	SHELL LUBE RECOMMENDATION
Piaggio	Vespa 125	Shell Advance AX7/AX5 10W-30
Piaggio	Vespa 150	Shell Advance AX7/AX5 10W-30
Piaggio	LX 125	Shell Advance AX7/AX5 10W-30
Piaggio	VXL 150	Shell Advance AX7/AX5 10W-30

SUZUKI



OEM	BIKE MODEL	SHELL LUBE RECOMMENDATION
Suzuki	Suzuki Access 125	Shell Advance AX7/AX5 10W-30
Suzuki	Swish	Shell Advance AX7/AX5 10W-30
Suzuki	Access 125	Shell Advance AX7/AX5 10W-30
Suzuki	Burgman Street	Shell Advance AX7/AX5 10W-30
Suzuki	Suzuki Skydrive	Shell Advance AX7/AX5 10W-30

HONDA



OEM	BIKE MODEL	SHELL LUBE RECOMMENDATION
Honda	Activa 125 / Activa 6G	Shell Advance AX7/AX5 10W-30
Honda	Aviator	Shell Advance AX7/AX5 10W-30
Honda	Grazia 125	Shell Advance AX7/AX5 10W-30
Honda	Dio	Shell Advance AX7/AX5 10W-30

MAHINDRA



OEM	BIKE MODEL	SHELL LUBE RECOMMENDATION
Mahindra	Gusto	Shell Advance AX7/AX5 10W-30
Mahindra	Avenis	Shell Advance AX7/AX5 10W-30
Mahindra	Gusto 125 / Gusto VX	Shell Advance AX7/AX5 10W-30
Mahindra	Rodeo / Rodeo RZ	Shell Advance AX7/AX5 10W-30
Mahindra	Duro / Duro DZ / Flyte	Shell Advance AX7/AX5 10W-30

HERO



OEM	BIKE MODEL	SHELL LUBE RECOMMENDATION
Hero	Kine	Shell Advance AX7/AX5 10W-30
Hero	Pleasure Plus/Destiny 125	Shell Advance AX7/AX5 10W-30
Hero	Maestro/Maestro Edge/Maestro 110	Shell Advance AX7/AX5 10W-30
Hero	Duet	Shell Advance AX7/AX5 10W-30
Hero	Pleasure	Shell Advance AX7/AX5 10W-30



CLEANS SCOOTER ENGINES
33% BETTER*
 THAN LEADING COMPETITOR



Shell
ADVANCE



*Claims are based on field trial results and lab based data (controlled environment) standard industry Micro-Caking Test.



**RACE
PROVEN,
ROAD
READY**

Shell
HELIX
Motor oils

WHY SHELL HELIX?

1

SHELL HELIX ULTRA IS THE ONLY MOTOR OIL USED BY FERRARI IN THEIR FORMULA ONE ENGINES



3



4

ASSOCIATED WITH LEADING OEMS

2



ACTIVE CLEANSING TECHNOLOGY



SMOOTHER, QUIETER AND MORE RESPONSIVE ENGINE



5

FLEXI MOLECULE* TECHNOLOGY

FLEXI MOLECULES MEAN MORE PROTECTION FOR YOUR ENGINE IN HIGH PRESSURE SITUATIONS

OUR ORIGINAL EQUIPMENT MANUFACTURER (OEMs) use Shell Helix Ultra with Pureplus Technology



"We only have five engines per season and we try to make sure that all of them run till the end of their life cycle, so it is important to use the right fuel and right oil, and in this case we choose Shell Helix Ultra."

"The demands and stresses on a Formula 1 engine are extraordinary. We need it to perform to its best every single time and last for multiple races. **Shell Helix Ultra helps to deliver both the protection and the performance we need to do the job on the track.**"

Sebastian Vettel
Scuderia Ferrari Driver



"Everyone at BMW Motorsport is delighted that we can count on Shell Helix Ultra in the DTM, as well as the Nürburgring 24 hours. **Shell Helix Ultra is perfectly suited to our motorsport projects.** We are putting our faith in these high-performance lubricants, and hope that the new partnership will allow us to lay the foundation for great success together on the racetrack."

Jens Marquardt,
BMW Motorsport Director



"Shell Helix Ultra and Maserati are talking to similar audiences – people who love their cars and want the very best performance."

Armando Bigliocchi,
Aftersales Department Maserati SpA

"**The engine of every Maserati leaving the production line currently is filled with Shell Helix Ultra.**"

Cara Tredget
Shell Auto OEM
Technology Manager



Shell and Hyundai have been global partners since 2005, with a global aftermarket agreement in place across 67 markets worldwide. Shell's technical partnership aims to co-engineer a winning edge to Hyundai Motorsport as it competes at the highest level of global rallying.

"**Since the introduction of Shell Helix Ultra motor oil with PurePlus Technology, Shell has helped Hyundai Motorsport to develop an extra 1.5 horsepower, representing an average of six seconds advantage at the end of each rally.**"

Michel Nandan,
Hyundai Team Principal

SHELL PUREPLUS TECHNOLOGY

An Entirely New Way of Making Synthetic Base Oils

What is **Shell PUREPLUS TECHNOLOGY**

Shell PurePlus Technology is a revolutionary gas-to-liquids process that converts natural gas into a crystal-clear base oil with virtually none of the impurities found in crude oil.

CRUDE OIL VERSUS GAS TO LIQUID ANALOGY

Traditional Crude Oil



Muddy water



Runs through small filter



Still impure

Gas to Liquids Process



Gas

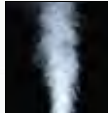

Steam



Pure liquid

**Based on sequence VG sludge test results using 0W-40

NO OTHER MOTOR OIL CAN KEEP YOUR ENGINES CLOSER TO FACTORY CLEAN**



*Average percentage achieved based on ILSAC GF-5 and Sequence IIIG pistons deposit tests using 5W-30.

***Shell Helix Ultra SN 5W-30: Average percentage achieved based on ILSAC GF-5 and Sequence IIIG pistons deposit tests using 5W-30.

KEY MESSAGES TO DELIVER:

- Shell has developed a new approach: making synthetic engine oils from NATURAL GAS
- Shell Helix Ultra is the FIRST engine oil made from natural gas
- It uses PurePlus Technology, a revolutionary process that delivers crystal clear base oil made from natural gas with no impurities – making it 99.5% pure.
- PurePlus Technology creates base oils with stronger molecular bonds, enabling Shell Helix Ultra to provide long-lasting engine performance

FLEXI MOLECULE TECHNOLOGY*

Flexi Molecules mean more protection for your engine in high pressure situations

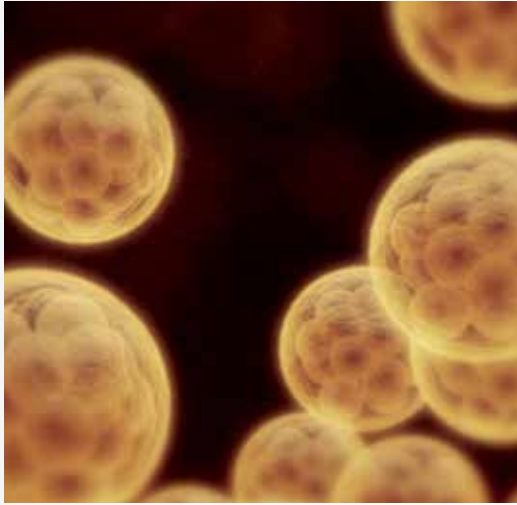

INACTIVE FLEXI MOLECULES UNDER LOW-PRESSURE

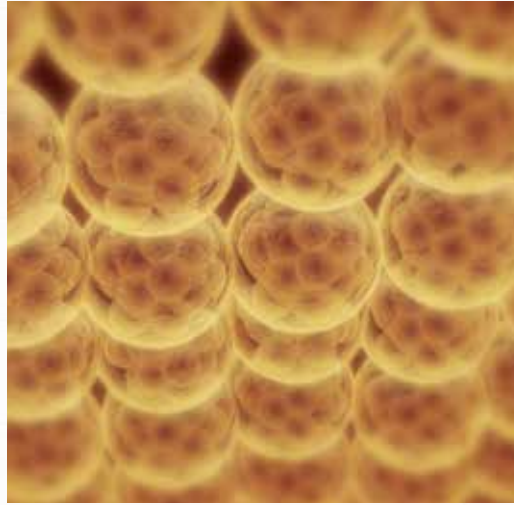

FLEXI MOLECULES COMING TOGETHER AFTER DETECTING HIGH PRESSURE ON CERTAIN ENGINE PARTS

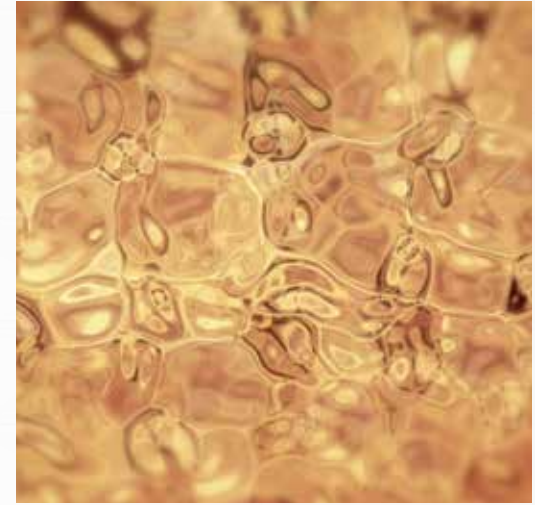

LAYER OF PROTECTION FORMED ON ENGINE PARTS EXPERIENCING INTENSE HEAT AND PRESSURE



KEY MESSAGES TO DELIVER:

Flexi-molecules remain inactive under low pressure and low temperature situations and activate under:

- High pressures to form a protective barrier on metal contacts, for example, in the valve train, to provide protection when most of the oil is squeezed or pushed out.
- High temperatures to form a protective barrier, for example, in cylinder liners and piston rings, and to provide oxidation control and instant protection from damage

ACTIVE CLEANSING TECHNOLOGY

Keep Your Engine Clean, Every Time You Drive

PREVENTS SLUDGE FORMATION

By locking away dirt particles



Sludge build-up due to dirt

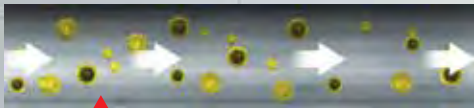

Shell Helix oils lock away dirt



**SMOOTHER, QUIETER AND
MORE RESPONSIVE ENGINE**

CLEANS UP SLUDGE

Left with inferior oils



Before



After clean up by Shell Helix





KEY MESSAGES TO DELIVER:

- Active Cleansing Technology cleans your engine in two ways : Prevents new sludge formation and it also cleans up sludge left by inferior oils
- **Benefits:** Smoother ride and more responsive engine in terms of pickup etc.

DETAILS:

- **It prevents formation of sludge** in your engine by locking away all the dirt and not letting it gel with each other. If the carbon particles are not kept separate, they combine to form sludge that harm your engine. Unlike water left after washing, oil stays inside the engine itself, so it is important to keep the dirt separate.
- **It also cleans-up sludge left by inferior oils.** Even if your previous oil doesn't keep the engine clean, Shell Helix cleans your car as you drive it. Active cleansing technology gives you a **smoother, quieter and more responsive engine.**

SHELL HELIX PRODUCT PORTFOLIO

	GOOD		BETTER			BEST			
PRODUCT	 HELIX HX3	 HELIX HX5	 TAXI OIL	 HELIX HX7	 HELIX HX6	 HELIX HX8	 HELIX SUV	 HELIX ULTRA	 HELIX ULTRA ECT
Benefits	Engine Protection	Designed for Total Engine Reliability with piston cleanliness and wear protection	Extended ODI of 10000 kms, Longer engine life	All round protection in daily driving conditions	Smart choice for everyday driving	Advanced Engine Performance and enhanced fuel efficiency	Expertly engineered for SUV engines	Ultimate Engine Performance, excellent sludge protection	Ultimate Engine Performance, Lower Carbon Emissions for BS6 Engines
Oil Type	Mineral Oil	Premium Mineral Oil	Semi-Synthetic Oil	Semi-Synthetic Oil	Semi-Synthetic Oil	Full Synthetic Oil	Full Synthetic Oil	Full Synthetic Oil	Full Synthetic Oil
Viscosity	20W-50	15W-40 & 10W-30	5W-30	10W-40	5W-30	5W-30 & 0W-20	5W-30	5W-40	0W-30
Specification	API SL	API SN	API SN+	API SN, ACEA A3/B3/B4	API SP	API SN+, ACEA A3/B3/B4 & API SP	API SP, ACEA C2	API SP	API SN, ACEA C2/C3
BS6 Compliance	NA	Petrol Engines*	Petrol Engines	Petrol Engines*	Petrol, Diesel & CNG Engines	Petrol Engines	Petrol & Diesel Engines	Petrol Engines	Petrol & Diesel Engines

SHELL HELIX PRODUCT TIERING



HELIX HX3
ENGINE
PROTECTION



HELIX HX5
TOTAL ENGINE
RELIABILITY



HELIX TAXI
EXTENDED ODI



HELIX HX6
SMART
CHOICE FOR
EVERYDAY
DRIVING



HELIX HX7
ALL ROUND
PROTECTION
IN DRIVING
CONDITIONS



HELIX HX8
ADVANCED
ENGINE
PERFORMANCE
& FUEL EFFICIENCY



HELIX SUV
EXPERTLY
ENGINEERED FOR
SUV ENGINES



HELIX ULTRA
ULTIMATE ENGINE
PERFORMANCE



HELIX ULTRA ECT
ULTIMATE
ENGINE
PERFORMANCE
(BS6)

SHELL HELIX ULTRA ECT



Today's four-wheelers need a motor oil that keeps pace with their changing demands and does more to improve engine's life & performance, as well as control emissions. With BS VI norms being implemented, it's important to upgrade engine oil to match engine requirements and be compatible with new hardware technology.

FEATURES

Shell Helix Ultra 0W-30 is a fully synthetic top-tier motor oil with the most advanced "Emission Compatible Technology" and "Low SAPS Formulation" – keeping the Diesel Particulate Filters (DPF) clean to maintain smooth engine performance.

SPECIFICATIONS

SAE 0W-30, API SN, ACEA C2/C3



KEEPS ENGINE CLOSE TO FACTORY CLEAN

No other motor oil can help provide the unsurpassed sludge protection as Shell Helix Ultra 0W-30.



2.6% MORE FUEL ECONOMY

It helps reduce engine friction and results in 2.6% greater fuel economy.



EXTENDED OIL DRAIN INTERVALS

Developed with special additives, it helps in low oil consumption that leads to excellent protection throughout the drain interval.

APPLICATIONS

- Shell Helix Ultra ECT can be used in all BS6 compliant modern gasoline, diesel and hybrid engines with or without Diesel Particulate Filters.
- It is backward complaint hence can be used in all BS4 petrol & diesel engines.

SHELL HELIX ULTRA

Shell
PUREPLUS
TECHNOLOGY



Every day driving in congested traffic can mean severe conditions for the car engine. No matter how well maintained engines are, they all generate dirt and acids that cause deposits to form. And in such tough environments, it's a challenge to keep engines in best conditions.

FEATURES

Shell Helix Ultra is a top tier fully **synthetic engine oil** formulated with unique PurePlus technology that converts natural gas into crystal clear base oil with no impurities offering the ultimate engine performance and unsurpassed protection to your car engine meeting the most stringent oil performance requirements.

SPECIFICATIONS

SAE 5W-40 , API SP , ACEA A3/B4



SUPERIOR ENGINE CLEANLINESS

65% superior piston cleanliness keeping engines close to factory clean so your car stays as good as new



FUEL ECONOMY

It helps reduce engine friction and results in 2.2% fuel economy



PERFORMANCE IN HOT N COLD TEMPERATURES

Exceptional performance in extreme temperatures ranging from -40°C to 1000°C



CARBON NEUTRAL

Carbon neutral with nature based carbon credits for lower emissions & a cleaner future

APPLICATIONS

- Shell Helix Ultra is recommended in all premium BS4 petrol and diesel engines and all BS 6 compliant petrol engines .

SHELL HELIX SUV

FLEXI
MOLECULE
TECHNOLOGY



Expertly engineered for SUV engines in urban & cruiser driving.

SUVs have powerful engines that operate under heavy loads in severe conditions. They need an engine oil that keeps them protected and performing in all challenging road conditions and driving situations.

FEATURES

Shell Helix SUV is a **fully synthetic engine oil** formulated with **Flexi Molecule Technology** to adapt and boost up the protection of engine when your vehicle needs the most. It provides **protection that adapts to every ride** from cold starts, long journeys, heavy loads and urban driving.



EXTENDS ENGINE LIFE



SUPERIOR WEAR PROTECTION



EXPERTLY ENGINEERED FOR URBAN & CRUISER DRIVING

SPECIFICATIONS

SAE 5W-30, API SP ACEA C2

APPLICATIONS

- Compatible for all **BS6 & BS4 petrol and diesel engines.**

SHELL HELIX HX8

FLEXI
MOLECULE
TECHNOLOGY



Engines have to perform under all sorts of different conditions – cold and heat, short and long distances . That’s why an oil is needed that protects your engine from inside, no matter what happens outside. With new engine-technologies and today’s tough driving conditions, an engine oil that can actively adapt to changing stress is very important.

FEATURES

Shell Helix HX8 is a **fully synthetic motor oil** which provides advanced protection in demanding driving conditions. Shell Helix HX8 features dynamic “Flexi- Molecule Technology” that constantly adapt to boost protection, where your engine needs it most. “An oil designed for advanced engine performance in city driving ,highway accelerations, steep hills and cold starts.”

SPECIFICATIONS

SAE 5W-30 , API SN+ , ACEA A3/B4



40% BETTER WEAR PROTECTION

All round protection of critical engine components.



30% FASTER OIL FLOW

Oil reaches critical components in lesser time for easier starting and faster warm up.



HIGHER VISCOSITY STABILITY & DEPOSIT CONTROL

Maintains viscosity and protects from deposits.



ENHANCED FUEL ECONOMY

Ride longer on the same amount of fuel.

APPLICATIONS

- Shell Helix HX8 is recommended in all premium BS4 petrol and diesel engines and all BS 6 compliant petrol engines .

SHELL HELIX HX8

FLEXI
MOLECULE
TECHNOLOGY



New modern cars with technological advancements and smaller engines face more challenges on road like stop start traffic, extreme pressure and temperature. Driven by the needs of fuel economy, lower emissions and changes in engine designs, modern cars need an exceptional engine oil.

FEATURES

Shell Helix HX8 0W-20 is a fully synthetic engine oil formulated with **Flexi Molecule Technology** that continuously adapts to boost protection when your engine needs the most.

SPECIFICATIONS

SAE 0W-20, API SP



FUEL ECONOMY WITH
LOWER EMISSIONS



DEPOSITS FREE
ENGINE



SUPERIOR ENGINE
PROTECTION



ULTIMATE ENGINE
PERFORMANCE

APPLICATIONS

- Helix HX8 0W-20 can be recommended for all BS VI and BS IV compliant petrol cars.

SHELL HELIX HX7



SPECIFICATIONS

SAE 10W-40 , API SN , ACEA A3/B4

When we drive, critical engine parts in our vehicles experience high pressures that increase the risk of engine wear, oil oxidation and deposit formation under all driving conditions.

These deposits under severe driving conditions make our engine sluggish and less responsive.

FEATURES

Shell Helix HX7 is synthetic technology motor oil equipped with unique **Active Cleansing Technology** that goes on cleaning and removing carbon deposits and keep your engine running clean and smooth.



40% BETTER WEAR PROTECTION

All round protection of critical engine components.

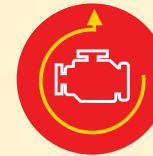

78% BETTER CORROSION PROTECTION

Protects engine components from corrosion and rust.



EXCELLENT RESISTANCE TO OIL DEGRADATION

Prevents oil thickening and provides protection throughout the drain interval.

APPLICATIONS

- Recommended for customers looking for semi-synthetic engine oil in mainstream petrol, diesel and engines.
- Suitable for use in all BS4 petrol and diesel engines and all BS6 compliant non-GDI petrol engines.

SHELL HELIX HX6



SPECIFICATIONS

SAE 5W-30, API SP/CF

APPLICATIONS

- Compatible for all BS6 & BS4 petrol, diesel and CNG engines

Smart choice for everyday driving.

Everyday driving can mean severe conditions for engine. No matter how well maintained engines are, they all generate deposits that can block the oilways, interfere with the function of the engine systems and reduces engine's responsiveness.

FEATURES

Shell Helix HX6 5W-30 is blended with **Synthetic & Active Cleansing Technology** that helps to keep your engine feeling like new. It makes your engine free from deposits that no other synthetic technology or mineral oil can surpass and gives **better protection to engine**.



ACTIVELY LOCKS AWAY
HARMFUL DEPOSITS



BETTER WEAR PROTECTION



LOW OIL CONSUMPTION FOR LESS FREQUENT TOP UPS

SHELL HELIX TAXI OIL



SPECIFICATIONS

SAE 5W-30, API SN PLUS/SN,
ACEA A3/B4

APPLICATIONS

- Recommended for all taxis operating on Diesel, Gasoline & CNG.
- Suitable for use in all BS4 petrol and diesel engines and all BS 6 compliant petrol engines

Today's taxi engines operate under high pressure and temperature. They are designed to deliver higher level of performance, improved fuel economy and lesser emissions than ever before. Higher running hours in the taxi segment coupled with frequent start-stop and idling leads to early oil change. Heavy traffic and multiple deliveries lead to start-stop driving, which causes sludge formation and deposits in engine, reducing the efficiency. Servicing & Maintenance cost is high due to wear and tear in taxi segment.

FEATURES

Shell Helix Taxi 5W-30 is a synthetic oil formulated with **Active Cleansing Technology** for smoother, quieter and more responsive engine.

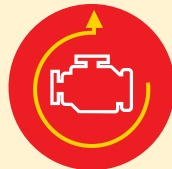

LONGER ENGINE LIFE

Helps to extend engine life by providing wear protection that no synthetic technology or mineral oil can surpass



EXTENDED ODI OF 10,000 KMS

Maintains oil properties for longer run



KEEPS ENGINE RESPONSIVE AND MAINTAINS PICK UP

Developed with special additives, it helps in low oil consumption that leads to excellent protection throughout the drain interval.

HELIX HX5

Shell Helix HX5 is a premium mineral oil formulated with Active Cleansing Technology that is designed to provide **total engine reliability**.

- It actively locks away harmful deposits and protects your engine from severe damage.
- Helps to remove sludge left behind by inferior oils and thus keeps your engine more responsive & Powerful



SPECIFICATIONS

API SN/CF, ACEA A3/B3,
SAE 15W-40, 10W-30

KEY BENEFITS

- Extends Engines Life
- More Responsive Engine

APPLICATIONS

- Recommended for all mainstream BS4 petrol, diesel and Gas engines.
- Suitable for use in BS6 petrol non-GDI engines.

HELIX HX3

Shell helix HX3 is entry tier mineral oil that helps provide reliable protection for older engines. formulated with Active Cleansing Technology to prevent engine wear and sludge deposits.



SPECIFICATIONS

SAE 20W-50 , API SL/CF

KEY BENEFITS

- Engine Protection From deposits and wear

APPLICATIONS

- Suitable for all old & entry tier car models.
- Can be used in petrol, diesel and CNG engines.

SHELL HELIX PRODUCT SARAL POINTS



**HELIX ULTRA ECT
0W-30**



**HELIX ULTRA
5W-40**



**HELIX HX8
5W-30**



**HELIX HX7
10W-40**



**HELIX TAXI
5W-30**



**HELIX HX5
15W-40, 10W-30**



**CONSUMER
CONCERN**

With BS VI norms implementation, it's important to upgrade engine oil to match engine requirements and new hardware technology

It's a challenge to keep engines in best performing conditions in today's tough environment.

With the development of new engine technology, critical engine parts of vehicles experience high pressures under all driving conditions

Engine deposits can block the oilways and interfere with functioning of the engine which means serious damage to engines.

Taxi Engines have higher running hours with frequent stop start driving leading to heavy sludge formation and early oil change

Deposits over a period of time make your engine sluggish and less responsive over a period of time



FEATURE

Most advanced Emissions Compatible Technology (ECT) that helps to keep diesel particulate filters (DPFs) & exhaust system clean to help maintain engine performance

Shell Helix Ultra formulated with PurePlus Technology that gives 99.9% clear base oil with no impurities

Shell Helix HX8 features dynamic FLEXI MOLECULE Technology that constantly adapts to boost protection where your engine needs it the most.

Shell HX7 features Active Cleansing Technology that locks away harmful deposits and keeps engine clean

Taxi oil is formulated with Active Cleansing Technology for smoother, quieter and responsive engine

Shell HX5 features Active Cleansing Technology that locks away harmful deposits and keeps engine clean



BENEFIT

Ultimate Engine Performance, Lower Emissions for BS6 engines.

Ultimate Engine Performance, Excellent Sludge Protection .

Advanced engine performance and enhanced fuel efficiency

All round protection under all driving conditions

Extended ODI of 10000 kms with low maintenance costs

Extends engine life with total engine reliability

Shell Helix Recommendation Chart*



MARUTI



MODEL	SUMP SIZE	SHELL LUBE RECOMMENDATION
PETROL		
ALTO, K 10, CELERIO, S-PRESSO	2.8	HELIX HX8 0W-20/HX8 5W-30
NEW DZIRE, NEW SWIFT, NEW WAGON R, A-STAR	2.8 to 3.1	HELIX HX8 0W-20/HX8 5W-30
SX4	4.3	HELIX HX8 0W-20/HX8 5W-30
BALENO, GRAND VITARA, VITARA BREZZA, CIAZ, SWIFT, DZIRE	3.1/3.2	HELIX HX8 0W-20/HX8 5W-30/HELIX ULTRA 5W-40
OMNI, EECO, OLD WAGON R	2.7, 4.2, 3.7/2.9	HELIX HX6 5W-30/TAXI 5W-30
ALTO 800, RITZ, OLD SWIFT, DZIRE TOUR	3.0 to 3.1	HELIX HX6 5W-30/TAXI 5W-30
NEW ERTIGA, S CROSS, XL6, JIMNY, FRONX	3.1/3.2/3.5/3.6/6.5	HELIX SUV 5W-30/HELIX HX8 0W-20/HELIX ULTRA 5W-40
ZEN/ESTILO, GYPSY/GYPSY KING, ESTEEM, VERSA, IGNIS	2.9/3.3, 4.2, 3.3, 5.0, 3.1	HELIX HX6 5W-30/HX8 0W-20
DIESEL		
BALENO, DZIRE, IGNIS, SWIFT	3.1	HELIX HX8 5W-30/HELIX ULTRA 5W-40
GRAND VITARA, VITARA BREZZA, CIAZ, S CROSS, SX4	3.2	HELIX HX8 5W-30/HELIX ULTRA 5W-40
CELERIO	3.4	HELIX HX6 5W-30
ERTIGA	3.2	HELIX SUV 5W-30

- All above listed products are applicable for BS6 petrol vehicles.
- Helix Ultra ECT, SUV and HX6 are applicable for both BS6 petrol and diesel vehicles.
- All the above mentioned products are applicable for both BS4 petrol and diesel vehicles.

HYUNDAI



MODEL	SUMP SIZE	SHELL LUBE RECOMMENDATION
PETROL BS VI		
AURA (GDI), I20 (GDI), VENUE (GDI), VERNA (GDI)	3.6	HELIX ULTRA ECT 0W-30/HELIX HX8 0W-20
CRETA (GDI), NEW TUCSON TURBO	4.3/4.0	HELIX ULTRA ECT 0W-30/HELIX HX8 0W-20
AURA (MPI), GRAND I10	3.6	HELIX ULTRA ECT 0W-30/HELIX HX8 0W-20
VENUE (MPI), VERNA (MPI)	3.8	HELIX ULTRA ECT 0W-30/HELIX HX8 0W-20
CRETA (MPI)/TUCSON/ALCAZAR	3.8, 4.0, 4.3	HELIX HX8 0W-20/HELIX SUV 5W-30
ELANTRA	4.0	HELIX HX8 5W-30/HELIX HX8 0W-20
I20 (NEW)	3.3 to 3.6/5.3	HELIX HX8 5W-30/HELIX HX8 0W-20
SANTRO (NEW)	3.3 to 3.6	HELIX HX8 0W-20
PETROL BS IV		
GRAND I10, ELITE 20, I20 ACTIVE, I20	3.6 to 4.2/5.3, 4.8	HELIX HX8 5W-30/HELIX ULTRA 5W-40
VERNA, XCENT	3.3/5.3	HELIX HX8 5W-30/HELIX ULTRA 5W-40
ACCENT	3.3 to 3.8/5.3, 4.8	HELIX HX8 5W-30/HELIX ULTRA 5W-40
CRETA	3.8, 4.0/5.3, 5.9	HELIX SUV 5W-30/HELIX ULTRA 5W-40
I10, SANTRO, EON, GETZ	4/7.6	HELIX HX6 5W-30
SONATA EMBERA/TRANSFORM	4.3/4.4	HELIX HX8 5W-30/HELIX ULTRA 5W-40
DIESEL BS VI		
I10, NEW I20, GRAND I10, AURA	4.7, 5.3, 4.7, 4.8	HELIX ECT 0W-30/HELIX HX6 5W-30
CRETA, TUCSON, ALCAZAR	4.8, 7.6, 4.8	HELIX SUV 5W-30/HELIX ULTRA ECT 0W-30
VERNA, ELANTRA, VENUE	4.8, 5.3/5.9, 4.8	HELIX ECT 0W-30
DIESEL BS IV		
ACCENT, ELANTRA, CRETA	5.3, 5.3/5.9, 5.3	HELIX ULTRA 5W-40/HELIX HX8 5W-30
I20, ELITE I20, I20 ACTIVE, VERNA	5.3	HELIX ULTRA 5W-40/HELIX HX8 5W-30
TUCSON, SANTA FE	7.6, 6.3 to 6.7	HELIX SUV 5W-30/HELIX ULTRA 5W-40
GRAND I10, XCENT	4.7	HELIX ULTRA 5W-40/HELIX HX8 5W-30
VENUE	5.3	HELIX ULTRA 5W-40/HELIX HX8 5W-30
SONATA, TRANSFORM	5.9/6.7	HELIX ULTRA 5W-40/HELIX HX8 5W-30

Shell Helix Recommendation Chart*



TOYOTA



MODEL	SUMP SIZE	SHELL LUBE RECOMMENDATION
PETROL		
ALTIS, COROLLA, CAMRY	4.2	HELIX HX8 5W-30/HELIX HX8 0W-20
CROSS, ETIOS, LIVA, YARIS	2.9	HELIX HX8 5W-30/HELIX HX8 0W-20
GLANZA 5.9	5.9	HELIX HX8 0W-20
INNOVA/CRYSTA/HYCROSS/ FORTUNER, LAND CRUISER	5.9, 6.9 to 7.5	HELIX SUV 5W-30/HELIX ULTRA 5W-40
URBAN CRUISER/CRUISER HYRYDER/ PRADO	5.9	HELIX SUV 5W-30/HELIX ULTRA 5W-40
VELLFIRE	4.2	HELIX ULTRA ECT 0W-30
DIESEL		
ALTIS, PRIUS	4.1, 4.2	HELIX HX6 5W-30
CROSS, ETIOS, LIVA	3.9	HELIX HX6 5W-30
FORTUNER, INNOVA	6.9	HELIX SUV 5W-30
INNOVA CRYSTA, FORTUNER LEGENDER, LAND CRUISER	6.9, 6.9/7.5, 6.9, 5.2, 9.2	HELIX SUV 5W-30
HILUX	5.6/6.9, 7.5	HELIX SUV 5W-30

- All above listed products are applicable for BS6 petrol vehicles.
- Helix Ultra ECT, SUV and HX6 are applicable for both BS6 petrol and diesel vehicles.
- All the above mentioned products are applicable for both BS4 petrol and diesel vehicles.

TATA



MODEL	SUMP SIZE	SHELL LUBE RECOMMENDATION
PETROL		
BOLT	4.0	HELIX HX8 5W-30
NEXON, TIAGO, TIGOR, PUNCH	3.5	HELIX HX8 5W-30/HELIX HX8 0W-20
ALTROZ, ZEST	3.5, 3.2	HELIX HX8 5W-30/HELIX HX8 0W-20
DIESEL		
HARRIER, HEXA	5, 7.5	HELIX SUV 5W-30/HELIX ULTRA ECT 0W-30
ZEST, XENON	4, 5.5	HELIX HX6 5W-30
INDICA VISTA, MANZA, INDIGO	5.5	HELIX HX6 5W-30
BOLT	3.2	HELIX HX6 5W-30
TIAGO, TIGOR	4.5	HELIX HX6 5W-30
NEXON, ARIA	5, 7.5	HELIX SUV 5W-30
SAFARI	5, 7.5	HELIX SUV 5W-30
SUMO GRANDE (DICOR)	7.5	HELIX HX7 10W-40/HELIX HX5 15W-40
SUMO GRANDE (TURBO)	6.8	HELIX HX7 10W-40/HELIX HX5 15W-40
ALTROZ	5.0	HELIX HX6 5W-30

FORD



MODEL	SUMP SIZE	SHELL LUBE RECOMMENDATION
FIGO PETROL/DIESEL	4/3.8	HELIX HX8 5W-30
ASPIRE PETROL/DIESEL	3.6, 4.8/3.8	HELIX HX8 5W-30
FIESTA PETROL/DIESEL	4.1/3.9	HELIX HX8 5W-30
IKON PETROL/DIESEL	4.1, 4.5/3.8	HELIX HX8 5W-30
ECOSPORT PETROL/DIESEL	4.1/3.8	HELIX SUV 5W-30
FUSION PETROL/DIESEL	4.1/3.8	HELIX HX6 5W-30
FORD FREESTYLE PETROL/DIESEL	4.8/3.8	HELIX HX8 5W-30
ENDEAVOUR DIESEL	8.6/9.7	HELIX SUV 5W-30
MUSTANG PETROL	7.6	HELIX SUV 5W-30

Shell Helix Recommendation Chart*



HONDA



MODEL	SUMP SIZE	SHELL LUBE RECOMMENDATION
PETROL		
ACCORD, AMAZE, CITY, CIVIC, JAZZ, MOBILIO, BRIO	3.6	HELIX HX8 0W-20/HELIX HX8 5W-30
WR-V, CR-V, ELEVATE	3.2 to 3.6	HELIX SUV 5W-30/HELIX ULTRA 5W-40
NEW CITY	3.2	HELIX HX8 0W-20
DIESEL		
AMAZE, CITY, JAZZ, MOBILIO, BRIO	4.2	HELIX HX6 5W-30
ACCORD, CIVIC	4.2	HELIX ULTRA ECT 0W-30
WR-V, CR-V	4.2	HELIX SUV 5W-30

NISSAN



MODEL	SUMP SIZE	SHELL LUBE RECOMMENDATION
EVALIA	4.5	HELIX HX7 10W-40
KICKS PETROL/DIESEL	4.3/4.55	HELIX ULTRA 5W-40/HELIX HX8 5W-30
MAGNITE/MAGNITE TURBOCHARGER	2.9/3.4	HELIX SUV 5W-30
MICRA PETROL/DIESEL	3/4.5	HELIX HX6 5W-30
SUNNY PETROL/DIESEL	3/4.5	HELIX HX6 5W-30
TEANA	4.6	HELIX HX6 5W-30
TERRANO PETROL/DIESEL	4.8/4.5	HELIX SUV 5W-30
X-TRAIL	5.2, 7.4	HELIX ULTRA 5W-40/HELIX HX8 5W-30

MAHINDRA



MODEL	SUMP SIZE	SHELL LUBE RECOMMENDATION
NEW BOLERO/BOLERO/SAFARI/INVADER	6.0/6.5	HELIX SUV 5W-30
BOLERO	6.0/6.5	HELIX SUV 5W-30
ALTURAS	6.0	HELIX SUV 5W-30
XUV 700, TUV 300, XUV 400, XUV 500, MARAZZO, SCORPIO/MHAWK/M2DI, IMPERIO, XYLO, QUANTO	6.0	HELIX SUV 5W-30
KUV100 NXT	3.5	HELIX SUV 5W-30
XUV 300 PETROL/DIESEL	4.0/6.0	HELIX SUV 5W-30
VERITO PETROL/DIESEL	3.5/4	HELIX HX6 5W-30
THAR	4.0/6.0	HELIX SUV 5W-30
JEEP	6.5	HELIX SUV 5W-30
NUVOSPORT	6.0	HELIX HX6 5W-30

RENAULT



MODEL	SUMP SIZE	SHELL LUBE RECOMMENDATION
PETROL		
TRIBER, KIGER	4.8	HELIX SUV 5W-30
DUSTER, KOLEOS	4.5	HELIX SUV 5W-30
CAPTUR, FLUENCE, LOGAN, PULSE, SCALA	4.5, 4.4, 3.3, 3.4, 4.5	HELIX HX8 5W-30
KWID	2.5	HELIX HX6 5W-30
DIESEL		
CAPTUR, FLUENCE, LODGY, LOGAN, PULSE, SCALA	4.5	HELIX HX8 5W-30
DUSTER, KOLEOS	5/7.4	HELIX SUV 5W-30

- All above listed products are applicable for BS6 petrol vehicles.
- Helix Ultra ECT, SUV and HX6 are applicable for both BS6 petrol and diesel vehicles.
- All the above mentioned products are applicable for both BS4 petrol and diesel vehicles.

Shell Helix Recommendation Chart*



FIAT



MODEL	SUMP SIZE	SHELL LUBE RECOMMENDATION
ABARTH	3.8	HELIX ULTRA ECT 0W-30
PALIO	3.8	HELIX HX6 5W-30
PUNTO	2.8/3.2	HELIX HX6 5W-30
LINEA	2.6, 2.8, 3.2	HELIX HX6 5W-30
UNO	3.4, 4.1	HELIX HX6 5W-30
JEEP COMPASS	5.2	HELIX SUV 5W-30
JEEP MERIDIAN	5.2	HELIX SUV 5W-30
JEEP WRANGLER	3.6	HELIX SUV 5W-30

CHEVROLET



MODEL	SUMP SIZE	SHELL LUBE RECOMMENDATION
AVEO	4.0	HELIX HX6 5W-30
BEAT PETROL/DIESEL	3.75/3.5	HELIX HX6 5W-30
CAPTIVA PETROL/DIESEL	6.2	HELIX HX8 5W-30
CORVETTE	7	HELIX HX8 5W-30
FORESTER	4.5	HELIX HX8 5W-30
OPTRA/SILVERADO	4	HELIX HX8 5W-30
CRUZE	5.4	HELIX HX8 5W-30
ENJOY PETROL/DIESEL	4/3.5	HELIX HX8 5W-30
OPTRA PETROL/DIESEL	3.75/4	HELIX HX8 5W-30
SAIL PETROL/DIESEL	3.75/3.2	HELIX HX8 5W-30
SPARK	3.2	HELIX HX6 5W-30
TAVERA	5.3	HELIX SUV 5W-30
TRAX CROSSOVER	4	HELIX HX8 5W-30
TRAILBLAZER	5.6	HELIX HX8 5W-30

VOLKSWAGEN



MODEL	SUMP SIZE	SHELL LUBE RECOMMENDATION
PETROL		
JETTA, POLO, VENTO, TOUAREG, PASSAT, AMEO	4.0	HELIX HX8 5W-30/HELIX ULTRA 5W-40
POLO, AMEO	3.0	HELIX HX8 5W-30/HELIX ULTRA 5W-40
VIRTUS	4/4.5	HELIX HX8 0W-20
TAIGUN	4/6.7	HELIX SUV 5W-30
TIGUAN	4/4.5	HELIX SUV 5W-30
BEETLE	3/4.3	HELIX HX8 0W-20
DIESEL		
JETTA, POLO, VENTO, PASSAT	4.5	HELIX ULTRA ECT 0W-30(BS6)/HELIX ULTRA 5W-40(BS4)
TOUAREG	6.7	HELIX ULTRA ECT 0W-30(BS6)/HELIX ULTRA 5W-40(BS4)

AUDI



MODEL	SUMP SIZE	SHELL LUBE RECOMMENDATION
PETROL		
FABIA, LAURA, OCTAVIA, RAPID, SUPERB, SLAVIA	3.8	HELIX HX8 5W-30/HELIX ULTRA 5W-40
KODIAQ, KUSHAQ	4.0/4.7, 4.3	HELIX SUV 5W-30
DIESEL		
FABIA, LAURA, OCTAVIA, RAPID	4.0	HELIX ULTRA ECT 0W-30(BS6)/HELIX ULTRA 5W-40(BS4)
SUPERB, YETI	4.3	HELIX ULTRA ECT 0W-30(BS6)/HELIX ULTRA 5W-40(BS4)
A4 OLD MODELS	4.5	HELIX ULTRA ECT 0W-30/HELIX ULTRA 5W-40
A4 NEW MODELS	5.0	HELIX ULTRA ECT 0W-30/HELIX ULTRA 5W-40

- All above listed products are applicable for BS6 petrol vehicles.
- Helix Ultra ECT, SUV and HX6 are applicable for both BS6 petrol and diesel vehicles.
- All the above mentioned products are applicable for both BS4 petrol and diesel vehicles.

Shell Helix Recommendation Chart*



SKODA



MODEL	SUMP SIZE	SHELL LUBE RECOMMENDATION
PETROL		
FABIA, LAURA, OCTAVIA, RAPID, SUPERB, SLAVIA	3.8	HELIX HX8 5W-30/HELIX ULTRA 5W-40
KODIAQ, KUSHAQ	4.0/4.7, 4.3	HELIX SUV 5W-30
DIESEL		
FABIA, LAURA, OCTAVIA, RAPID	4.0	HELIX ULTRA ECT 0W-30(BS6)/HELIX ULTRA 5W-40(BS4)
SUPERB, YETI	4.3	HELIX ULTRA ECT 0W-30(BS6)/HELIX ULTRA 5W-40(BS4)

BMW



MODEL	SUMP SIZE	SHELL LUBE RECOMMENDATION
3 SERIES	6.5	HELIX ULTRA ECT 0W-30/HELIX ULTRA 5W-40
X3	5.4	HELIX ULTRA ECT 0W-30/HELIX ULTRA 5W-40
5 SERIES/X5	6.5	HELIX ULTRA ECT 0W-30/HELIX ULTRA 5W-40
8D	6.5	HELIX ULTRA ECT 0W-30/HELIX ULTRA 5W-40
6 SERIES	7.7	HELIX ULTRA ECT 0W-30/HELIX ULTRA 5W-40
X6, 7 SERIES/X6, M SERIES/M3/M5/M6	7.2	HELIX ULTRA ECT 0W-30/HELIX ULTRA 5W-40
X1	4.3	HELIX ULTRA ECT 0W-30/HELIX ULTRA 5W-40
1 SERIES	6.5	HELIX ULTRA ECT 0W-30/HELIX ULTRA 5W-40
Z4, Z8, GT, 6 SERIES	8.0	HELIX ULTRA ECT 0W-30/HELIX ULTRA 5W-40

AUDI



MODEL	SUMP SIZE	SHELL LUBE RECOMMENDATION
A4 OLD MODELS	4.5	HELIX ULTRA ECT 0W-30/HELIX ULTRA 5W-40
A4 NEW MODELS	5.0	HELIX ULTRA ECT 0W-30/HELIX ULTRA 5W-40
TT	4.5	HELIX ULTRA ECT 0W-30/HELIX ULTRA 5W-40
A6/A8/A3	6.0	HELIX ULTRA ECT 0W-30/HELIX ULTRA 5W-40
R8	9.0	HELIX ULTRA ECT 0W-30/HELIX ULTRA 5W-40
Q7	8.5	HELIX ULTRA ECT 0W-30/HELIX ULTRA 5W-40
Q3/Q5	9.5	HELIX ULTRA ECT 0W-30/HELIX ULTRA 5W-40
S5 SPORTBACK	3.8/4.5	HELIX ULTRA ECT 0W-30/HELIX ULTRA 5W-40
RS7 SPORTBACK	8.2	HELIX ULTRA ECT 0W-30/HELIX ULTRA 5W-40
RS 6	6.9	HELIX ULTRA ECT 0W-30/HELIX ULTRA 5W-40

MERCEDEZ-BENZ



MODEL	SUMP SIZE	SHELL LUBE RECOMMENDATION
A CLASS/B CLASS	5.5/7	HELIX ULTRA ECT 0W-30/HELIX ULTRA 5W-40
C CLASS/E CLASS	5.5/8.5	HELIX ULTRA ECT 0W-30/HELIX ULTRA 5W-40
CLS CLASS	9.0	HELIX ULTRA ECT 0W-30/HELIX ULTRA 5W-40
GL CLASS/M CLASS	8.5/11/5	HELIX ULTRA ECT 0W-30/HELIX ULTRA 5W-40
S CLASS	6.5/9	HELIX ULTRA ECT 0W-30/HELIX ULTRA 5W-40
SLK CLASS	5.5/8	HELIX ULTRA ECT 0W-30/HELIX ULTRA 5W-40

- All above listed products are applicable for BS6 petrol vehicles.
- Helix Ultra ECT, SUV and HX6 are applicable for both BS6 petrol and diesel vehicles.
- All the above mentioned products are applicable for both BS4 petrol and diesel vehicles.

Shell Helix Recommendation Chart*



PORSCHE



MODEL	SUMP SIZE	SHELL LUBE RECOMMENDATION
BOXSTER/CAYENNE	7.0	HELIX ULTRA ECT 0W-30
PANAMERA/CARRERA	7.0	HELIX ULTRA ECT 0W-30
V6/V8	7/8.5	HELIX ULTRA ECT 0W-30

KIA



MODEL	SUMP SIZE	SHELL LUBE RECOMMENDATION
SONET	3.4	HELIX SUV 5W-30/ECT 0W-30
SELTOS	3.8/4.2	HELIX SUV 5W-30/ECT 0W-30
CARENS	4.0	HELIX HX8 0W-20
CARNIVAL	6.5	HELIX SUV 5W-30/ECT 0W-30

VOLVO



MODEL	SUMP SIZE	SHELL LUBE RECOMMENDATION
S80/XC60/XC90	5.0 TO 6.0	HELIX ULTRA ECT 0W-30
V40/V60	5.2/5.6/5.9	HELIX ULTRA ECT 0W-30
S60/S90	6.8/5.9	HELIX ULTRA ECT 0W-30

MG



MODEL	SUMP SIZE	SHELL LUBE RECOMMENDATION
HECTOR	4.8	HELIX SUV 5W-30/ECT 0W-30
HECTOR PLUS	4.8	HELIX SUV 5W-30/ECT 0W-30
ASTOR	4.8	HELIX SUV 5W-30/ECT 0W-30
GLOSTER	4.8	HELIX SUV 5W-30/ECT 0W-30

- All above listed products are applicable for BS6 petrol vehicles.
- Helix Ultra ECT, SUV and HX6 are applicable for both BS6 petrol and diesel vehicles.
- All the above mentioned products are applicable for both BS4 petrol and diesel vehicles.



Shell
HELIX Motor oils

Designed for ultimate engine performance

DRIVE ON

RIGHT ENGINE OILS FOR EVERY TRUCK.



Shell
RIMULA

WHY SHELL RIMULA

1

**SHELL RIMULA
IS THE HIGHEST
SELLING HDDEO
IN THE WORLD***



2



LOWER MAINTENANCE AND OPERATING COSTS

ACIDS
CONTROL

DEPOSIT
CONTROL

WEAR
CONTROL

3



**PROVEN PERFORMANCE
IN INDIA**

- Increased overhaul period
- Reduced maintenance costs

* As per Kline Report 2010

SHELL RIMULA PROTECTS AGAINST ACIDS, DEPOSITS AND WEAR

The Main Challenges for a Diesel Engine Oil are:

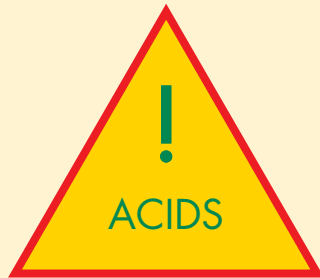

Shell Rimula

PROTECTS FROM CORROSION

PREVENTS RING STICKING, LINER WEAR. OIL REACHES ALL PARTS WITHOUT BLOCKAGE

KEEPS METAL SURFACES APART. REDUCES WEAR



End Benefit

LESSER MAINTENANCE AND DOWNTIME COSTS

- GOOD PICKUP
- MORE RESPONSIVENESS
- LESSER MAINTENANCE COSTS

- LONGER ENGINE LIFE
- REDUCED OIL CONSUMPTION
- INCREASED OVERHAUL PERIOD



ALSO PROTECTS AGAINST OIL THICKENING DUE TO EXCESS SOOT. **RIMULA R4** PROVIDES BEST SOOT HANDLING



PROTECTION THROUGHOUT THE OIL DRAIN INTERVAL WITH IMPROVED CLEANLINESS



DYNAMIC PROTECTION

SHELL PRODUCT RANGE FOR COMMERCIAL VEHICLE



RIMULA R2 EXTRA
VALUE FOR MONEY



RIMULA R3 X
TRIPLE PROTECTION AGAINST WEAR, DEPOSITS AND HEAT



RIMULA LD3
PERFORMANCE & SAVINGS IN URBAN DRIVING CONDITIONS



RIMULA R4
EXTENDED ENGINE LIFE WITH DYNAMIC PROTECTION



RIMULA R4 L
EXTENDED ENGINE LIFE WITH DYNAMIC PROTECTION
(BS6 COMPLIANT)



RIMULA R5 LE
REDUCED TOTAL COST OF OWNERSHIP
& SUPERIOR ENGINE PROTECTION

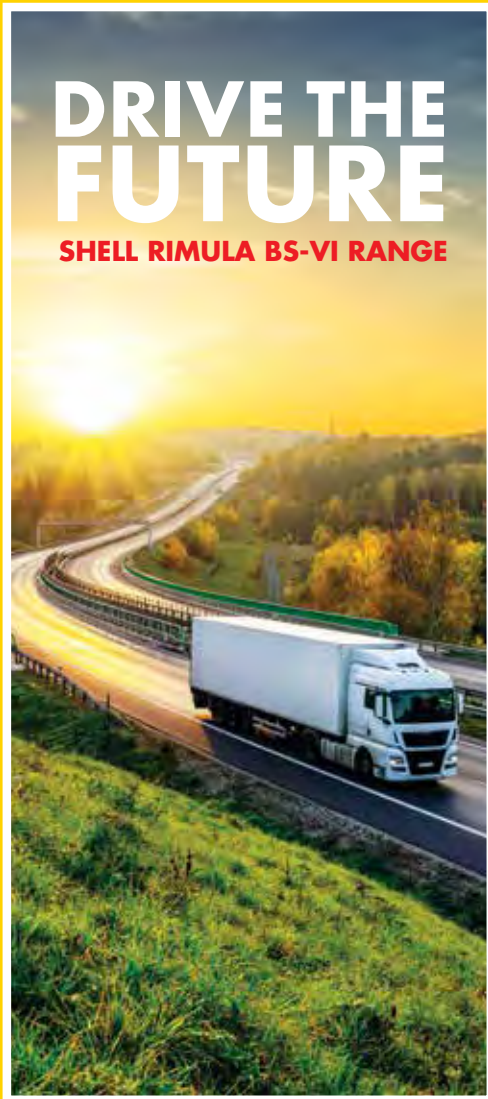

Shell Rimula R5 LE

SPECIFICATIONS

SAE 10W40, API CK-4

PACK SIZES

1, 15L

APPLICATION

Backward Compliant- BSIII, IV, VI



SPECIFICATIONS

SAE 10W30, API CK-4

PACK SIZES

3L

APPLICATION

Suitable for All MLCVs/Mini-trucks



DYNAMIC PROTECTION PLUS
TECHNOLOGY FOR SUPERIOR
ENGINE PROTECTION



ODI OF UP TO 1 LAKH KMS
WITH LESS STOPPAGES FOR
MAINTENANCE AND OIL CHANGE



SAVINGS IN FUEL COSTS WITH 2%
MILEAGE IMPROVEMENT



Shell Rimula R4 L

SPECIFICATIONS

SAE 15W40, API CK-4

PACK SIZES

1L, 10L, 15L

APPLICATION

Backward Compliant- BSIII, IV, VI



LOWER EMISSIONS
AND REDUCED COSTS



ENHANCED ENGINE
PROTECTION



IMPROVED
ENGINE LIFE

The low SAPS formulation BS6 range of engine oils helps to protect the catalysts and diesel particulate filters in BS6 engines. These oils are backward compatible with BS III and BS IV engines

SHELL RIMULA R4



SPECIFICATIONS

SAE 15W-40, API CI-4 Plus

FEATURES

Shell Rimula R4 is a premium engine oil, designed to protect modern engines with turbochargers, intercooling devices and exhaust gas re-circulation. Powered by Dynamic Protection, it adapts to multiple conditions within the engine to help minimize maintenance and operating cost by providing a versatile oil for modern fleets.



**DYNAMIC PROTECTION
DELIVERS CLEANER
ENGINES AND BETTER
OXIDATION CONTROL**



**LOWER TOTAL
COST OF
OWNERSHIP**



**EXTENDED
ENGINE
LIFE**

APPLICATION

Suitable for all engine models, recommending CI-4 Plus



SHELL RIMULA R3X



SPECIFICATIONS

SAE Viscosity Grade: 15W-40, API CH-4.

FEATURES

Shell Rimula R3 X oils provide **triple action protection against wear, deposits and heat**, continuously adapting to the needs of your engine for protection in on- and off-highway applications. No matter how hot, cold, steep, dusty, muddy or extended your operations, the energised Protection of Shell Rimula R3 works relentlessly to control acid, deposit and wear



**LONGER ENGINE
LIFE WITH
IMPROVED
WEAR RESISTANCE**



**EFFICIENT
OPERATION
THROUGH
EXCEPTIONAL
DEPOSIT CONTROL**



**CONTINUED
PROTECTION WITH
INCREASED HEAT
RESISTANCE**

APPLICATION

Suitable for all engine models recommending CH4.



SHELL RIMULA LD3



SPECIFICATIONS

SAE Viscosity Grade: 15w40. API CH4.

FEATURES

Shell Rimula LD3 are specially designed for light duty trucks to tackle the challenging urban driving conditions. They protect the engine in heavy load carrying, multiple deliveries & city driving conditions so that customer can spend less time and money on repairs and more time on the road.



FIGHTS WEAR & SLUDGE DURING CONSTANT START STOP DRIVING



MAINTAINS VEHICLE PICKUP EVEN WITH HEAVY LOADS ON INCLINED ROADS



ENGINE PROTECTION IN HIGH IDLING & HEAVY TRAFFIC CONDITIONS

APPLICATION

Suitable for All MLCVs/Mini-trucks running for loading & delivery applications



SHELL RIMULA R2 EXTRA



SPECIFICATIONS

SAE Viscosity Grade: 15w40. API CF4.

FEATURES

Shell Rimula R2 Extra contains up to 20% more active deposit control additives than more basic oils thus providing additional protection against deposits



PROTECTIVE POWER:

Ensures reliable and consistent protection against deposits and wear

APPLICATION

Suitable for Wide range of turbocharged & non turbocharged diesel engines under normal operation, older trucks and buses, agricultural tractors



Dumdaar Quality Dumdaar Engine Oil

Shell HD series

Shell HD Series adapts and protects under full range of pressures and temperatures, delivering soot control and wear protection.



Passes 10 **Shell**
quality parameters



Blended in
ISO approved facility



Matches **International**
quality standards



SPECIFICATIONS
SAE 15W-40, API C14+

PACK SIZE
1L, 10L, 15L



SPECIFICATIONS
SAE 15W-40, API CH4

PACK SIZE
1L, 10L, 15L



SPECIFICATIONS
SAE 15W-40, API CF4

PACK SIZE
1L, 10L, 15L

SHELL PRODUCT RANGE FOR AGRICULTURE

AGRICULTURE



Rimula R1

Enhanced protection
against corrosion
& wear



Rimula R3

Best in class protection
of 450 hours



Rimula R2

Reliable Protection



Rimula R4

Dynamic Protection for
extended engine life

SHELL RIMULA R1 MULTI

Shell Rimula R1 Multi Energised Protection oils use proven performance additives to fight engine wear, for continuous protection and consistent performance.



**ENHANCED PROTECTION
AGAINST CORROSION &
WEAR**

SPECIFICATIONS

SAE Viscosity Grade: 20W-40
API CF4.



SHELL RIMULA R3 X

Shell Rimula R3 X oils provide **triple action protection against wear, deposits and heat**



**ENJOY INCREASED
SAVINGS WITH 450
HOURS OF OPERATION**

SPECIFICATIONS

SAE Viscosity Grade: 15W40
API CH4



SHELL RIMULA PRODUCT PORTFOLIO

Product	 APDEO	 RIMULA R1	 RIMULA R2 EXTRA	 RIMULA R3X	 RIMULA LD3	 RIMULA R4	 RIMULA R4 L	 RIMULA R5 LE
Positioning	Good standard of engine cleanliness	Enhanced protection against corrosion & wear	Reliable protection against deposits	Triple protection against acid, deposits and wear	Less time & money on repairs in challenging urban driving conditions	Dynamic Protection for extended engine life	Extended engine life with dynamic protection for BS6 engines	Superior engine protection and savings in TCO with 2% FE & 1 lakh ODI
Oil Type	Mineral	Mineral	Mineral	Mineral	Mineral	Mineral Oil	Mineral Oil	Synthetic Oil
Viscosity	SAE 20W-40	SAE 20W-40	SAE 15W-40	SAE 15W-40	SAE 15W-40	SAE 15W-40	SAE 15W-40	10W-40
Specification	API CF	API CF4	API CF4	API CH4	API CH4	API CI4+	API CK4	API CK4
BS6 readiness	NA	NA	NA	NA	NA	NA	YES	YES

Shell Rimula Truck Recommendation Chart*



Keep moving with our widerange of products



Shell
RIMULA

HCV

OEM	Vehicle Segment	Model	Pre BS6 Norms	Post BS6 Norms
TATA	HCV construct	2518TC, 2528K, 3123K	Rimula R4 15W-40 CI4+	Shell Rimula R4L 15W-40, CK4 / Rimula R5 10W-40, CK4
TATA	HCV construct	3118 TC	Rimula R4 15W-40 CI4+	Shell Rimula R4L 15W-40, CK4 / Rimula R5 10W-40, CK4
TATA	HCV Cargo	1613, 2525, 2516	Rimula R4 15W-40 CI4+	Shell Rimula R4L 15W-40, CK4 / Rimula R5 10W-40, CK4
TATA	HCV Cargo	1616, 3118TC, 4018TC	Rimula R4 15W-40 CI4+	Shell Rimula R4L 15W-40, CK4 / Rimula R5 10W-40, CK4
TATA	HCV Cargo	2518TC, 3518 TC, 3723TC	Rimula R4 15W-40 CI4+	Shell Rimula R4L 15W-40, CK4 / Rimula R5 10W-40, CK4
TATA	HCV Cargo	Prima 4923TC, 4023.S, 4923.S, 4028 TC, 4928.S	Rimula R4 15W-40 CI4+	Shell Rimula R4L 15W-40, CK4 / Rimula R5 10W-40, CK4
TATA	HCV Rigid	Signa 4018, 4021, 4625, 5525, 5530	Rimula R4 15W-40 CI4+	Shell Rimula R4L 15W-40, CK4 / Rimula R5 10W-40, CK4
Ashok Leyland	HCV	Ecomet 1616, 1916, 1920, 1415, 1615, 1815	Rimula R4 15W-40 CI4+	Shell Rimula R4L 15W-40, CK4 / Rimula R5 10W-40, CK4
Ashok Leyland	HCV	4019, 4023, 4923, 2516, 3116, 3718	Rimula R4 15W-40 CI4+	Shell Rimula R4L 15W-40, CK4 / Rimula R5 10W-40, CK4
Eicher	HCV Cargo	2016, 3025, 3531, 4040	Rimula R4 15W-40 CI4+	Shell Rimula R4L 15W-40, CK4 / Rimula R5 10W-40, CK4
Eicher	HCV Tippers	Terra 16, Terra 25	Rimula R4 15W-40 CI4+	Shell Rimula R4L 15W-40, CK4 / Rimula R5 10W-40, CK4
Bharat Benz	HCV	2523 R, 2523 C, 3123 R, 2528 C, 3128 C	Rimula R4 15W-40 CI4+	Shell Rimula R4L 15W-40, CK4 / Rimula R5 10W-40, CK4
Bharat Benz	HCV	Tractor Trailer 4023 T, 4028 T, 4029 T, 4928 T	Rimula R4 15W-40 CI4+	Shell Rimula R4L 15W-40, CK4 / Rimula R5 10W-40, CK4
Bharat Benz	HCV	Axor 4940 T, 4948 T	Rimula R4 15W-40 CI4+	Shell Rimula R4L 15W-40, CK4 / Rimula R5 10W-40, CK4
Bharat Benz	HCV	Atros (Thunderbolt) 3143 C, 4048 C	Rimula R4 15W-40 CI4+	Shell Rimula R4L 15W-40, CK4 / Rimula R5 10W-40, CK4
TATA	MCV	1109	Rimula R4 15W-40 CI4+	Shell Rimula R4L 15W-40, CK4 / Rimula R5 10W-40, CK4
TATA	MCV	1112	Rimula R4 15W-40 CI4+	Shell Rimula R4L 15W-40, CK4 / Rimula R5 10W-40, CK4
TATA	MCV	LPO1512	Rimula R4 15W-40 CI4+	Shell Rimula R4L 15W-40, CK4 / Rimula R5 10W-40, CK4

MCV

OEM	Vehicle Segment	Model	Pre BS6 Norms	Post BS6 Norms
Ashok Leyland	MCV	Ecomet 1012, 1212, 1214	Rimula R4 15W-40 CI4+	Shell Rimula R4L 15W-40, CK4 / Rimula R5 10W-40, CK4
Bharat Benz	MCV	1217 C, 1617 R, 1618 C, 1917R, 1917C, 1017	Rimula R4 15W-40 CI4+	Shell Rimula R4L 15W-40, CK4 / Rimula R5 10W-40, CK4
Eicher	MCV	Pro series 1059, 1075, 1080, 1090, 1095, 1110	Rimula R4 15W-40 CI4+	Shell Rimula R4L 15W-40, CK4 / Rimula R5 10W-40, CK4
TATA	LCV	407, 410	Rimula R4 15W-40 CI4+	Shell Rimula R4L 15W-40, CK4 / Rimula R5 10W-40, CK4
TATA	LCV	709, 712, 909, 912	Rimula R4 15W-40 CI4+	Shell Rimula R4L 15W-40, CK4 / Rimula R5 10W-40, CK4
TATA	LCV	Y1 Ultra Truck/Bus	Rimula R4 15W-40 CI4+	Shell Rimula R4L 15W-40, CK4 / Rimula R5 10W-40, CK4

LCV/SCV

OEM	Vehicle Segment	Model	Pre BS6 Norms	Post BS6 Norms
Ashok Leyland	LCV	Boss 912LE, 1212LE	Rimula R4 15W-40 CI4+	Shell Rimula R4L 15W-40, CK4 / Rimula R5 10W-40, CK4
Eicher	LCV	Pro series 1059, 1075, 1080, 1090, 1095, 1110	Rimula R4 15W-40 CI4+	Shell Rimula R4L 15W-40, CK4 / Rimula R5 10W-40, CK4
Bharat Benz	LCV	914 R, 1214 R, 914 R (bus)	Rimula R4 15W-40 CI4+	Shell Rimula R4L 15W-40, CK4 / Rimula R5 10W-40, CK4
TATA	SCV	Ace/Super Ace/IRIS	Rimula R2 15W-40, CF4/Rimula LD3 15W-40, CH4	Rimula R5 10W-30, CK4
Ashok Leyland	SCV	Dost	Rimula R2 15W-40, CF4/Rimula LD3 15W-40, CH4	Rimula R5 10W-30, CK4
Mahindra	SCV	Maxxima, Maxxima Plus	Rimula R2 15W-40, CF4/Rimula LD3 15W-40, CH4	Rimula R5 10W-30, CK4
Mahindra	SCV	Jeeto, Champion	Rimula R2 15W-40, CF4/Rimula LD3 15W-40, CH4	Rimula R5 10W-30, CK4

*The oil recommended at Shell Lubricants is only indicative purposes based on the technical specifications of vehicles manufactured. Please refer to the vehicle manufacturers service manual for exact specifications.

Shell Agri Recommendation Chart*



**Shell
RIMULA**

MAHINDRA

MODEL	GOOD PERFORMANCE	BETTER PERFORMANCE
Yuvraj 215 NXT, 255 DI Power Plus	Shell Rimula R1 20W-40, CF4	Shell Rimula R3X 15W-40, CH4 / Rimula R4 15W-40, CI4+
265 DI, 265 Power Plus, 275 DI, 275 ECO, 405 DI, 475 DI, 575 DI	Shell Rimula R1 20W-40, CF4	Shell Rimula R3X 15W-40, CH4 / Rimula R4 15W-40, CI4+
595 DI	Shell Rimula R1 20W-40, CF4	Shell Rimula R3X 15W-40, CH4 / Rimula R4 15W-40, CI4+
275 DI TU, 295 DI, 395 DI	Shell Rimula R1 20W-40, CF4	Shell Rimula R3X 15W-40, CH4 / Rimula R4 15W-40, CI4+

TAFE

MODEL	GOOD PERFORMANCE	BETTER PERFORMANCE
555 DI DLX, 555 Power Plus, 605 DI DLX, 605 MAT, Arjun 555 DI, Arjun 605 DI PS, Arjun Novo 605 DI	Shell Rimula R1 20W-40, CF4	Shell Rimula R3X 15W-40, CH4 / Rimula R4 15W-40, CI4+
MF 9500	Shell Rimula R1 20W-40, CF4	Shell Rimula R3X 15W-40, CH4 / Rimula R4 15W-40, CI4+
MF 241 DI, MF 7250 DI, MF 9000 DI	Shell Rimula R1 20W-40, CF4	Shell Rimula R3X 15W-40, CH4 / Rimula R4 15W-40, CI4+
Tafe 35 DI, Tafe 45 DI	Shell Rimula R1 20W-40, CF4	Shell Rimula R3X 15W-40, CH4 / Rimula R4 15W-40, CI4+
Tafe 5900 DI 2WD	Shell Rimula R1 20W-40, CF4	Shell Rimula R3X 15W-40, CH4 / Rimula R4 15W-40, CI4+
Tafe 5900 DI 4WD	Shell Rimula R1 20W-40, CF4	Shell Rimula R3X 15W-40, CH4 / Rimula R4 15W-40, CI4+
Tafe 7502 DI 2WD	Shell Rimula R1 20W-40, CF4	Shell Rimula R3X 15W-40, CH4 / Rimula R4 15W-40, CI4+
Tafe 7502 DI 4WD	Shell Rimula R1 20W-40, CF4	Shell Rimula R3X 15W-40, CH4 / Rimula R4 15W-40, CI4+
Tafe 8502 DI 2WD	Shell Rimula R1 20W-40, CF4	Shell Rimula R3X 15W-40, CH4 / Rimula R4 15W-40, CI4+
Tafe 8502 DI 4WD	Shell Rimula R1 20W-40, CF4	Shell Rimula R3X 15W-40, CH4 / Rimula R4 15W-40, CI4+

SWARAJ

MODEL	GOOD PERFORMANCE	BETTER PERFORMANCE
978 FE NEW, 855 FE NEW	Shell Rimula R1 20W-40, CF4	Shell Rimula R3X 15W-40, CH4 / Rimula R4 15W-40, CI4+
735 FE NEW, 855 FE, 744 FE, 939 FE, 724 XM, 724 XM Orchard, 825 XM	Shell Rimula R1 20W-40, CF4	Shell Rimula R3X 15W-40, CH4 / Rimula R4 15W-40, CI4+
834 XM, 735 XM, 841 XM	Shell Rimula R1 20W-40, CF4	Shell Rimula R3X 15W-40, CH4 / Rimula R4 15W-40, CI4+
843 XM, 744 XM, 855 XM	Shell Rimula R1 20W-40, CF4	Shell Rimula R3X 15W-40, CH4 / Rimula R4 15W-40, CI4+
841 XM, 843 XM, 744 XM, 855 XM	Shell Rimula R1 20W-40, CF4	Shell Rimula R3X 15W-40, CH4 / Rimula R4 15W-40, CI4+

*The oil recommended at Shell Lubricants is only indicative purposes based on the technical specifications of vehicles manufactured. Please refer to the vehicle manufacturers service manual for exact specifications.

Shell Agri Recommendation Chart*



**Shell
RIMULA**

ESCORTS

MODEL	GOOD PERFORMANCE	BETTER PERFORMANCE
Farmtrac 60 (LoadMaxx)	Shell Rimula R1 20W-40, CF4	Shell Rimula R3X 15W-40, CH4 / Rimula R4 15W-40, CI4+
Farmtrac 60 (SuperMaxx)		
Farmtrac Champion (LoadMaxx)		
Farmtrac Champion (SuperMaxx)		
Farmtrac Hero XP (LoadMaxx)		
Farmtrac 6050 (LoadMaxx)		
Farmtrac 6050 (SuperMaxx)		
Farmtrac 6055 (LoadMaxx)		
Farmtrac 6055 (SuperMaxx), Farmtrac 6055 (UltraMaxx)		
6-Farmtrac 6045 (LoadMaxx), Farmtrac 6045 (SuperMaxx)		
Farmtrac 6065, Farmtrac 6066	Shell Rimula R1 20W-40, CF4	Shell Rimula R3X 15W-40, CH4 / Rimula R4 15W-40, CI4+
Powertrac 445 (LoadMaxx)	Shell Rimula R1 20W-40, CF4	Shell Rimula R3X 15W-40, CH4 / Rimula R4 15W-40, CI4+
Powertrac 445 (SuperMaxx)	Shell Rimula R1 20W-40, CF4	Shell Rimula R3X 15W-40, CH4 / Rimula R4 15W-40, CI4+
Powertrac 439 (LoadMaxx)	Shell Rimula R1 20W-40, CF4	Shell Rimula R3X 15W-40, CH4 / Rimula R4 15W-40, CI4+
Powertrac 439 (SuperMaxx)	Shell Rimula R1 20W-40, CF4	Shell Rimula R3X 15W-40, CH4 / Rimula R4 15W-40, CI4+
Powertrac 439 DS plus (SuperMaxx)	Shell Rimula R1 20W-40, CF4	Shell Rimula R3X 15W-40, CH4 / Rimula R4 15W-40, CI4+
Powertrac 439 DS plus Euro (SuperMaxx)	Shell Rimula R1 20W-40, CF4	Shell Rimula R3X 15W-40, CH4 / Rimula R4 15W-40, CI4+
Powertrac 439 DS plus Euro (LoadMaxx)	Shell Rimula R1 20W-40, CF4	Shell Rimula R3X 15W-40, CH4 / Rimula R4 15W-40, CI4+
Powertrac 445 DS plus	Shell Rimula R1 20W-40, CF4	Shell Rimula R3X 15W-40, CH4 / Rimula R4 15W-40, CI4+

*The oil recommended at Shell Lubricants is only indicative purposes based on the technical specifications of vehicles manufactured. Please refer to the vehicle manufacturers service manual for exact specifications.

Shell Agri Recommendation Chart*



**Shell
RIMULA**

SONALIKA

MODEL	GOOD PERFORMANCE	BETTER PERFORMANCE
DI 60	Shell Rimula R1 20W-40, CF4	Shell Rimula R3X 15W-40, CH4 / Rimula R4 15W-40, CI4+
Gardentrac 20	Shell Rimula R1 20W-40, CF4	Shell Rimula R3X 15W-40, CH4 / Rimula R4 15W-40, CI4+
Sonalika 26, Sonalika 110	Shell Rimula R1 20W-40, CF4	Shell Rimula R3X 15W-40, CH4 / Rimula R4 15W-40, CI4+
DI Baagban	Shell Rimula R1 20W-40, CF4	Shell Rimula R3X 15W-40, CH4 / Rimula R4 15W-40, CI4+
DI 730	Shell Rimula R1 20W-40, CF4	Shell Rimula R3X 15W-40, CH4 / Rimula R4 15W-40, CI4+
DI 35, DI 42, DI 45, DI 47, DI 50, DI 55, DI 740 III, DI 745 III	Shell Rimula R1 20W-40, CF4	Shell Rimula R3X 15W-40, CH4 / Rimula R4 15W-40, CI4+
DI 60 MM Super	Shell Rimula R1 20W-40, CF4	Shell Rimula R3X 15W-40, CH4 / Rimula R4 15W-40, CI4+
DI 740	Shell Rimula R1 20W-40, CF4	Shell Rimula R3X 15W-40, CH4 / Rimula R4 15W-40, CI4+
DI 75	Shell Rimula R1 20W-40, CF4	Shell Rimula R3X 15W-40, CH4 / Rimula R4 15W-40, CI4+
Worldtrac 75, WT 90, Sonalika 75N	Shell Rimula R1 20W-40, CF4	Shell Rimula R3X 15W-40, CH4 / Rimula R4 15W-40, CI4+

JOHN DEERE

MODEL	GOOD PERFORMANCE	BETTER PERFORMANCE
5205, 5105, 5305D, 3028EN, 6120B, 5039D, 5060E, 5050D, 5310	Shell Rimula R1 20W-40, CF4	Shell Rimula R3X 15W-40, CH4 / Rimula R4 15W-40, CI4+
5042C, 5038D, 5039C, 5036C	Shell Rimula R1 20W-40, CF4	Shell Rimula R3X 15W-40, CH4 / Rimula R4 15W-40, CI4+

NEW HOLLAND

MODEL	GOOD PERFORMANCE	BETTER PERFORMANCE
3630 TX, 3230 NX, 3600 -2 TX, Excel 6010	Shell Rimula R1 20W-40, CF4	Shell Rimula R3X 15W-40, CH4 / Rimula R4 15W-40, CI4+

*The oil recommended at Shell Lubricants is only indicative purposes based on the technical specifications of vehicles manufactured. Please refer to the vehicle manufacturers service manual for exact specifications.

COMPLETE PROTECTION FOR YOUR VEHICLE

Shell **RIMULA**

HEAVY DUTY DIESEL ENGINE OILS

- Shell Rimula R5LE 10W40 API CK4
- Shell Rimula R4 L 15W40 API CK4
- Shell Rimula R4 15W40 API C14+
- Shell Rimula R3X 15W40 API CH4
- Shell Rimula R2X 15W40 API CF4

Shell **SPIRAX**

POWER STEERING OIL

- Shell Spirax S1 ATF TASA

Shell **SPIRAX**

GEAR OIL

- Shell Spirax S2 G 80W90
- Shell Spirax S2 G 140
- Shell Spirax S2 G 90

Shell **SPIRAX**

AXLE OIL

- Shell Spirax S2 A 85W140

Shell **GADUS**

WHEEL BEARING GREASE

- Shell Gadus S1 V160 3
- Shell Gadus S2 V150C 3

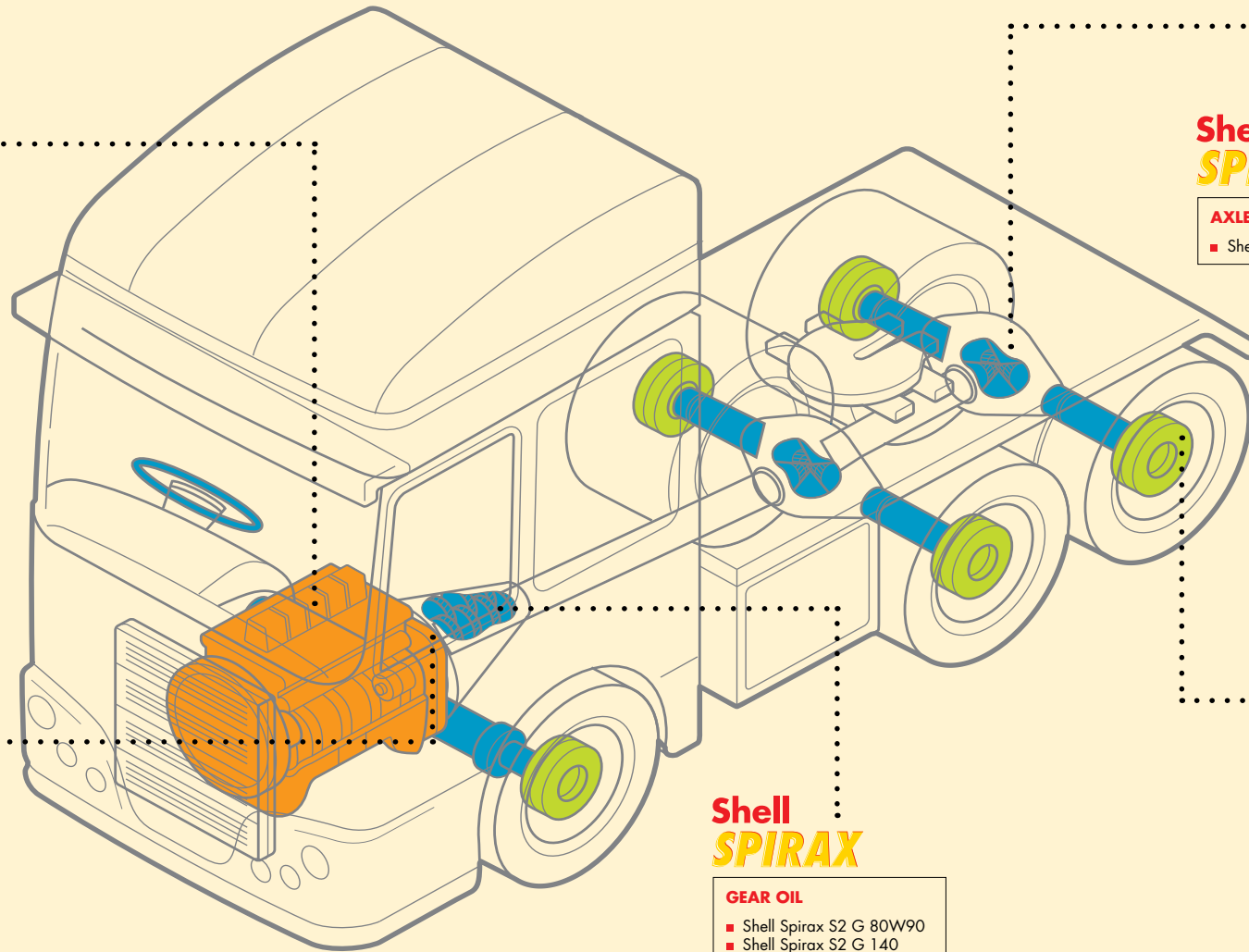

SHELL SPIRAX - TRANSMISSION OILS

KEY BENEFITS

Wear and corrosion protection → ■ Longer equipment life
■ Lower maintenance costs

Good oxidation stability → ■ Long oil life
■ Longer protection
■ Lesser operating costs

Shell Spirax S2 G



SPECIFICATIONS

SAE Viscosity Grade: 80W-90,
90 and 140 API Service
Classification GL-4

APPLICATIONS

- For manual gearboxes operating under high-speed/low torque and low-speed/high torque conditions
- Gear Sets for medium applications like light duty commercial vehicles and passenger cars. Not suitable for heavy duty hypoid gears
- Rear Axles for medium applications like lightly loaded gear sets of ancillary equipment in commercial vehicles

Shell SPIRAX S2 A 85W-140



SPECIFICATIONS

SAE Viscosity Grade: 85W-140
API Service Classification GL-5

APPLICATIONS

- Automotive axle units, including automotive transmissions & differentials
- Gear sets in stationary and ancillary equipment
- Hypoid gear axles
- Other automotive transmission units operating under high speed – shockload, high speed – low torque or low speed – high torque conditions

Shell Agri UTTO



Shell Agri UTTO

With special “low noise” additives and high quality base oil, you get:



Superior
Performance



Increased
Savings



Reduced
Maintenance Cost

Universal tractor transmission oil is a common oil for gears, hydraulics and wet brakes. UTTO is a specialized lubricating oil designed to work in multiple systems within a tractor.



Gears
Wear protection
from heavy loads



Hydraulics
Power transfer
without power loss



Wet brake
Friction properties
for noiseless braking

UTTO oils help to optimize performance, reduce maintenance needs, and prolong the lifespan of the machinery.

SHELL GADUS - PREMIUM GREASE

Best-in-class grease with Shell-patented "Micro-Fibre Technology"

Developed with Shell-patented thickener technology for higher mechanical durability even under extreme conditions



Shell **Gadus S2 V150C 3**

SHELL GADUS S2 PROVIDES RELIABLE PROTECTION AGAINST:



HIGH TEMPERATURE

Shell Gadus S2 doesn't leak out even at high temperature situations like sudden and frequent braking of the vehicle.



CONTAMINATION

Shell Gadus S2 repels contaminants like water and dirt which can find their way to hub-and-bearings and provides protection against rusting



OVERLOAD

Shell Gadus S2 remains stable and protects the hub-and-bearings under extreme pressure like overloading of vehicle.

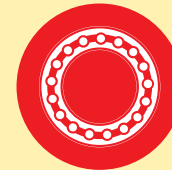

LONGER BEARING LIFE

Long-lasting protection against heavy loading and shock loads

Premium red coloured grease developed especially to suit Indian conditions. Long drain interval of 100,000 kms to ensure longer on-road performance

MP3 RANGE

Multipurpose Grease



Enhanced Water resistance for wet applications



Stays in Place
Wear protection



Prevents leakages
Improved oil separation



Patented
Thickener technology
Stable Pricing



SPECIFICATIONS

NLGI 3, Colour : Light Brown,
Pack Sizes : 0.5, 1, 2, 5, 180 kg

APPLICATION



Trucks in the tough Indian roads run in condition exposed to dirt and water and need a reliable grease that provides protection in such conditions



Grease that resists thinning and “stays in place” Ensures protection with built in water resistance Stable pricing and value for money



Good performance at competitive price

SHELL COOLANT

Shell Coolants are based on superior Organic Additive Technology (OAT) that outperforms conventional coolants, so that customers can spend less time and money on repairs and more time on the road.



Shell Coolants Extra
Water Based Coolant

Shell Coolants Longlife Plus
Antifreeze Coolant

KEY BENEFITS



EXCELLENT PROTECTION

Shell Coolants provides superior protection to engine in all-weather from overheating and corrosion so that engine can perform at its best and reduce maintenance cost.



LONG SERVICE LIFE

Shell Coolants have high inhibitor levels for extended service to keep vehicle on the road and out of the workshop.



COMPATIBILITY WITH HARD WATER

Shell Coolants are compatible with hard water (up to 700 ppm).

MAIN APPLICATIONS:

- Shell Coolants are suitable to be used in cars, light duty trucks, light commercial vehicles, heavy duty trucks and tractors
- Suitable to be used for all major vehicle manufacturers

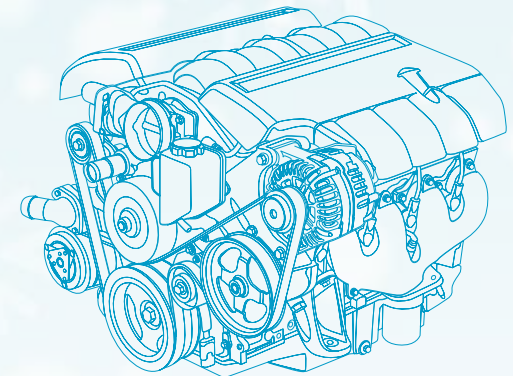

SHELL ENGINE OIL 3 WHEELER

Shell Engine Oil provides Active Cleansing Technology that prevents deposit and helps in smooth running of engine. It also provides high engine protection at higher temperature for longer engine life.



CUSTOMER BENEFITS



ENHANCED ENGINE PROTECTION



EXTENDED ENGINE LIFE



LOW MAINTENANCE COST

SPECS:

API SL/CF

PACK SIZES:

1L, 500 ML

APPLICATION:

SUITABLE FOR CNG, LPG, PETROL & DIESEL ENGINES



EXCELLENCE IN EVERY DROP

SHELL INDIA MARKETS PVT. LTD.

Level 9A, Two Horizon Centre, Golf Course Road,
DLF Phase V, Sector - 43, Gurgaon - 122002, Haryana
Tel.: +91 124 6661500, email: contactus.india@shell.com